

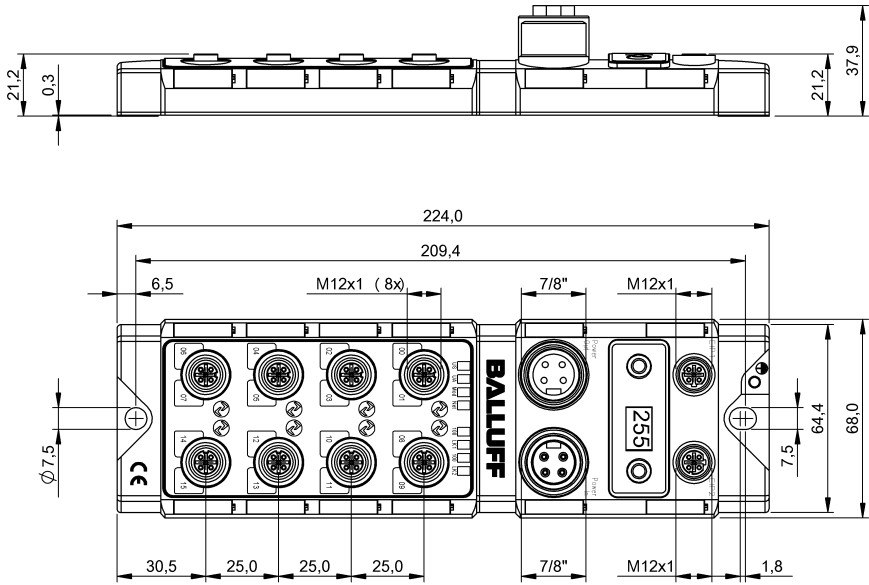

**BNI EIP-508-105-Z015-C06**  
EtherNet/IP™ IP67 modules  
User's Guide



## Table of Contents

<b>1</b>	<b>Notes</b>	<b>3</b>
1.1.	Structure of the guide	3
1.2.	Typographical Conventions	3
	Enumerations	3
	Actions	3
	Syntax	3
	Cross-references	3
1.3.	Symbols	3
1.4.	Abbreviations	3
1.5.	Deviating views	3
<b>2</b>	<b>Safety</b>	<b>4</b>
2.1.	Intended Use	4
2.3.	General Safety Notes	4
2.4.	Resistance to Aggressive Substances	4
	Dangerous Voltage	4
<b>3</b>	<b>First Steps</b>	<b>5</b>
3.1.	Module Overview	5
3.2.	Mechanical Connection	6
3.3.	Electrical Connection	6
	Power Supply	6
	Grounding	6
	Ethernet IP Interface	6
	IO-Link Port	7
	Port	7
<b>4</b>	<b>Technical Data</b>	<b>8</b>
4.1.	Dimensions	8
4.2.	Mechanical Data	8
4.3.	Operating Conditions	8
4.4.	Electrical Data	8
4.5.	Ethernet	9
4.6.	Function Indicators	9
	Module Status	9
	Port	10
<b>5</b>	<b>Integration</b>	<b>11</b>
5.1.	Integration into the Rockwell RS Logix 5000	11
5.2.	Data Configuration	15
5.3.	Configuration Data	15
	Module configuration	15
	IO-Link port configuration	15
<b>6</b>	<b>Configuration via Explicit Messages</b>	<b>16</b>
	QuickConnect	16
	Rockwell Automation Products that are Compatible with QuickConnect	17
	Example with Rockwell Components	18
	PLC Program	19
	Fault State	22
	Enable/Disable Fault State	22
	Fault State Action	22
	IO-Link Device Parameterization	23
	Read IO-Link Parameter	23
	Write IO-Link Parameter	25
<b>7</b>	<b>Process Data</b>	<b>26</b>

7.1. Process Data Inputs	26
Standard Input Data	26
IO-Link Input Data	27
7.2. Process Data Outputs	28
Standard Output Data	28
IO-Link Output Data	28
8 Display	29
8.1. General	29
8.2. Address Specifications	29
8.3. Control and Display	29
8.4. Display Information	29
8.5. Design and Symbols	30
8.6. Startup	30
8.7. Main Menu	30
8.8. IP Setup	31
8.9. Network Config	31
8.10. Edit mode	32
8.11. Module Information	33
8.12. General Information	33
9 Web Server	34
9.1. General	34
9.2. Navigation / Info	35
9.3. Login/Logout	36
9.4. "Home" dialog	37
9.5. "Ports" dialog	39
No appropriate IODD uploaded	39
Appropriate IODD uploaded	40
9.6. "IODD" dialog	42
9.7. "Config" dialog	43
9.8. "Log" dialog	45
10 Appendix	47
10.1. Included in the Scope of Delivery	47
10.2. Order Number	47
10.3. Ordering Information	47
Notes	48

- 1.1. Structure of the guide** This guide is arranged so that one chapter builds upon the other.  
Chapter 2: Basic safety instructions  
Chapter 3: Main steps for installing the device  
.....
- 1.2. Typographical Conventions** The following typographical conventions are used in this manual.
- Enumerations** Enumeration is shown in the form of bulleted lists.
- Entry 1,
  - Entry 2
- Actions** Action instructions are indicated by a preceding triangle. The result of an action is indicated by an arrow.
- Action instruction 1.
  - ↪ Result of action.
  - Action instruction 2.
- Actions can also be indicated as numbers in parentheses.
- (1) Step 1
  - (2) Step 2
- Syntax** Numbers:  
Decimal numbers are shown without additional information (e.g. 123),  
Hexadecimal numbers are shown with the additional indicator hex (e.g., 00<sub>hex</sub>) or the prefix "0x" (e.g., 0x00).
- Cross-references** Cross-references indicate where additional information on the topic is located.
- 
- 1.3. Symbols**
-  **Note**  
This symbol indicates general notes.
- 
-  **Attention!**  
This symbol indicates a security notice which must be observed.
- 
- 1.4. Abbreviations**
- |     |                               |
|-----|-------------------------------|
| BNI | Balluff Network Interface     |
| I   | Standard input port           |
| EIP | EtherNet/IP™                  |
| EMC | Electromagnetic compatibility |
| FE  | Function ground               |
| O   | Standard output port          |
- 1.5. Deviating views** Product views and illustrations in this manual may differ from the actual product. They are intended only as illustrative material.

## 2 Safety

### 2.1. Intended Use

The BNI EIP-... is a decentralized IO-Link, input and output module for connecting to the EtherNet/IP™ network.

### 2.2. Installation and Startup



#### Attention!

Installation and startup are to be performed by trained technical personnel only. Skilled specialists are people who are familiar with the work such as installation and the operation of the product and have the necessary qualifications for these tasks. Any damage resulting from unauthorized tampering or improper use shall void warranty and liability claims against the manufacturer. The operator is responsible for ensuring that the valid safety and accident prevention regulations are observed in specific individual cases.

### 2.3. General Safety Notes

#### Commissioning and inspection

Before commissioning, carefully read the User's Guide.

The system must not be used in applications in which the safety of persons depends on the function of the device.

#### Intended use

Warranty and liability claims against the manufacturer shall be rendered void by damage from:

- Unauthorized tampering
- Improper use
- Use, installation or handling contrary to the instructions provided in this User's Guide.

#### Obligations of the owner/operator

The device is a piece of equipment in accordance with EMC Class A. This device can produce RF noise. The owner/operator must take appropriate precautionary measures against this for its use. The device may be used only with a power supply approved for this. Only approved cables may be connected.

#### Malfunctions

In the event of defects and device malfunctions that cannot be rectified, the device must be taken out of operation and protected against unauthorized use.

Intended use is ensured only when the housing is fully installed.

### 2.4. Resistance to Aggressive Substances



#### Attention!

The BNI modules always have good chemical and oil resistance. When used in aggressive media (such as chemicals, oils, lubricants and coolants, each in a high concentration (i.e. too little water content)), the material must first be checked for resistance in the particular application. No defect claims may be asserted in the event of a failure or damage to the BNI modules caused by such aggressive media.

### Dangerous Voltage



#### Attention!

Before working on the device, switch off its power supply.



#### Note

In the interest of continuous improvement of the product, Balluff GmbH reserves the right to change the technical data of the product and the content of these instructions at any time without notice.

3.1. Module Overview

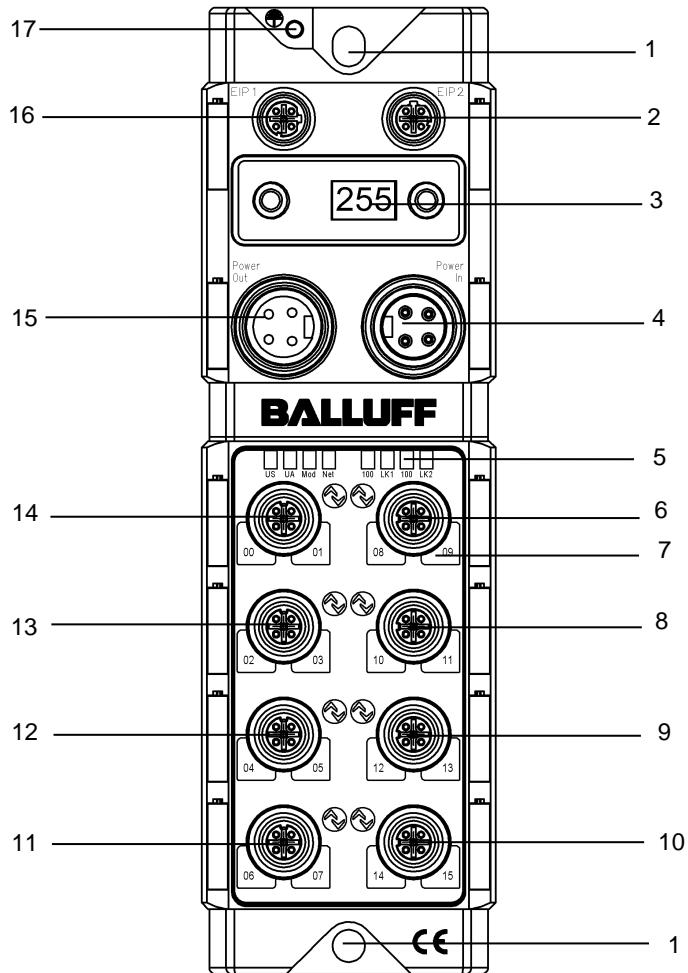

Figure – Overview: BNI EIP-508-105-Z015-C06

- |   |                                    |    |                                |
|---|------------------------------------|----|--------------------------------|
| 1 | Mounting hole                      | 10 | Port 7 (IO-Link, standard I/O) |
| 2 | EtherNet/IP™ port 2                | 11 | Port 3 (IO-Link, standard I/O) |
| 3 | Display                            | 12 | Port 2 (IO-Link, standard I/O) |
| 4 | Power supply, input                | 13 | Port 1 (IO-Link, standard I/O) |
| 5 | Status LED: communication / module | 14 | Port 0 (IO-Link, standard I/O) |
| 6 | Port 4 (IO-Link, standard I/O)     | 15 | Power supply, output           |
| 7 | Pin/port LED: signal status        | 16 | EtherNet/IP™ port 1            |
| 8 | Port 5 (IO-Link, standard I/O)     | 17 | Ground connection              |
| 9 | Port 6 (IO-Link, standard I/O)     |    |                                |

## 3 First Steps

### 3.2. Mechanical Connection

The module is secured by means of two M6 screws and two washers. Insulation support is available separately.

### 3.3. Electrical Connection

#### Power Supply

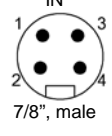
	Pin	Function	Description
 7/8", male	1	+24 V	Actuator supply
	2	+24 V	Module / sensor supply
	3	0 V	GND module / sensor and actuator supply
	4		

#### Note



Where possible, use a separate power source to supply the sensor/bus and actuator with power.  
Total current < 9 A The total current of all modules must not exceed 9 A even in the case of series connection of the actuator supply.

#### Grounding

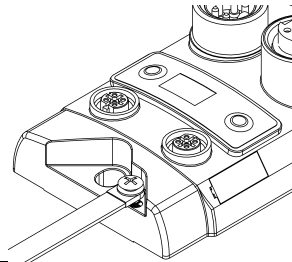

#### Note

The functional ground connection between housing and machine must have a low impedance and be as short as possible.

#### Ethernet IP Interface

M12, D-coded, female

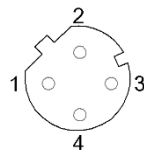

Pin	Function	
1	Tx+	Transmit Data +
2	Rx+	Receive Data +
3	Tx-	Transmit Data -
4	Rx-	Receive Data -

### 3 First Steps

#### IO-Link Port

M12, A-coded, female

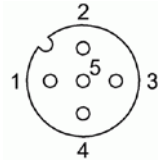

Pin	Function
1	+24 V, 1.6 A
2	Input/output 2A
3	GND
4	IO-Link
5	n.a.

#### Port

	Port	
	0-3	4-7
BNI EIP-508-105-Z015-C06	IN / OUT / IO-Link	



**Note**

For the digital sensor inputs, refer to guideline on inputs EN 61131-2, Type 2.



**Note**

The total current of the module must not exceed 9 A.



**Note**

Unused I/O ports must be provided with cover caps to comply with degree of protection IP67.

## 4 Technical Data

### 4.1. Dimensions

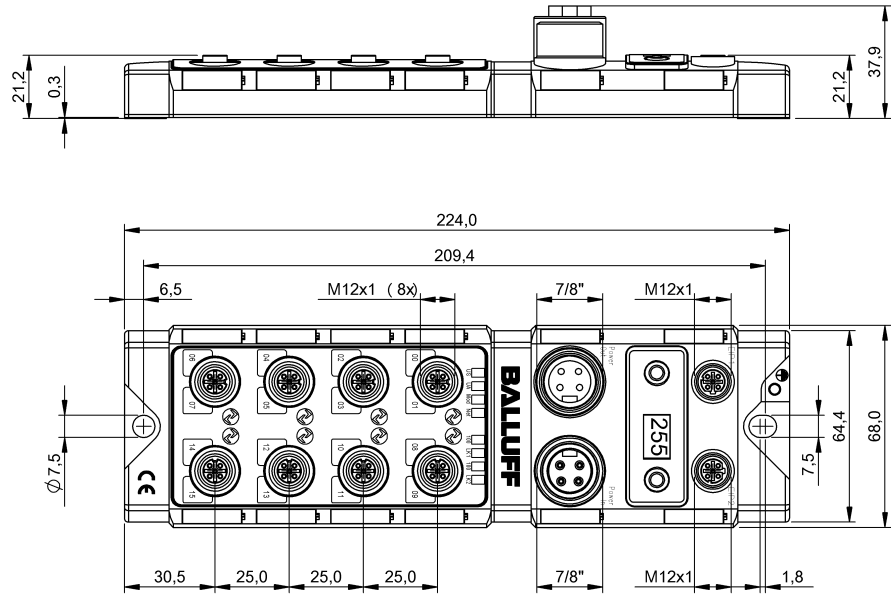

### 4.2. Mechanical Data

Housing material	Die case zinc, matt nickel plated
Enclosure rating per IEC 60529	IP 67 (only when plugged-in and threaded-in)
Supply voltage	7/8" 4-pin, connector / female
Input ports / output ports	M12, A-coded (8x female)
Dimensions (W x H x D in mm)	68 x 224 x 37.9
Type of mounting	Screw mounting with 2 mounting holes
Ground strap installation	M4
Weight	Approx. 670 g

### 4.3. Operating Conditions

Operating temperature $T_a$	-5 °C ... 70 °C
Storage temperature	-25 °C ... 70 °C

### 4.4. Electrical Data

Supply voltage	18...30.2 V DC, in accordance with EN 61131-2
Ripple	< 1%
Input current at 24 V	130 mA

## 4 Technical Data

### 4.5. Ethernet

Ethernet IP port	2 x 10Base/100Base Tx
Connection for Ethernet IP port	M12, D-coded, female
Cable types in accordance with IEEE 802.3	Shielded, twisted pair min. STP CAT 5/ STP CAT 5e
Data transmission rate	10/100 Mbps
Max. cable length	100 m
Flow control	Half-duplex/full-duplex (IEEE 802.3x pause)

### 4.6. Function Indicators

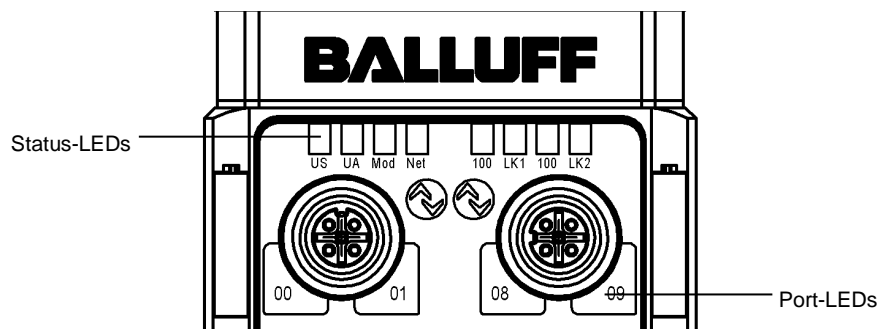

### Module Status

LED	Display	Description
UA	Green	Output power OK
	Red, flashing	Low output power (< 18V)
	Red	No output power (< 11V)
US	Green	Input power OK
	Red, flashing	Low input power (< 18V)
Mod	Green, flashing	Incorrect or no configuration of the module
	Green	Module is working
	Red, flashing	Fixed bus clock is not possible
	Red-green, flashing	Initial sequence
Netw ork	Off	Module has no IP address
	Green, flashing	Module has IP, but no connection established
	Green	Connection established
	Red, flashing	Connection timeout
	Red-green, flashing	Initial sequence
100	Off	Bus clock: 10 Mbps
	Yellow	Bus clock: 100 Mbps
LNK	Green	Data transfer

4 Technical Data

Port

Each port has two bicolored LEDs for displaying the I/O statuses.

	Display	Status	Description
I/O port	Off	I/O status	The status of the input or output pins is 0
	Yellow	I/O status	The status of the input or output pins is 1
	Red, flashing	Short-circuit	Short-circuit between pin 1 and 3
	Red	Short-circuit	Short-circuit at dedicated pin
IO-Link port	Green	IO-Link	IO-Link communication active
	Green, flashing	IO-Link	No IO-Link communication
	Green, rapidly flashing	IO-Link	IO-Link pre-operate during data storage
	Red	Short-circuit	Short-circuit at pin 4
	Red, flashing quickly	IO-Link	Validation failed / Data storage failed / Wrong device for data storage

## 5 Integration

### 5.1. Integration into the Rockwell RS Logix 5000

Here you see an example of how the module can be integrated into a Rockwell RS Logix 5000:

First go offline

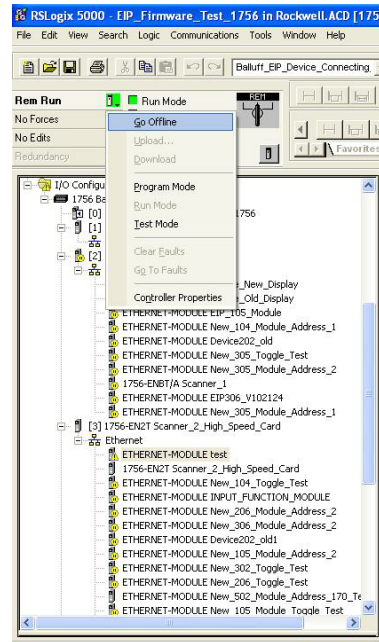

Right-click Ethernet (on the correct scanner card)  
Select a new module

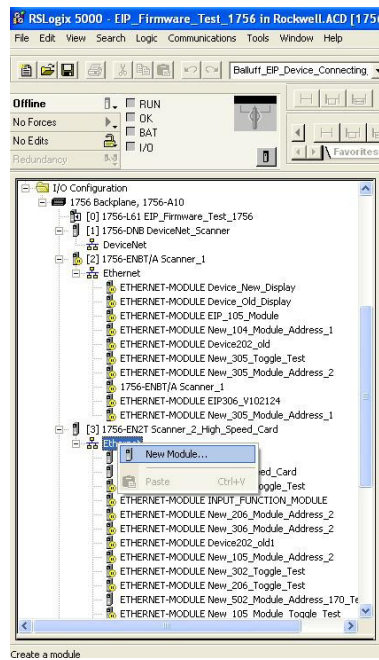

## 5 Integration

Then select the general Ethernet module as the ETHERNET module in the communication path

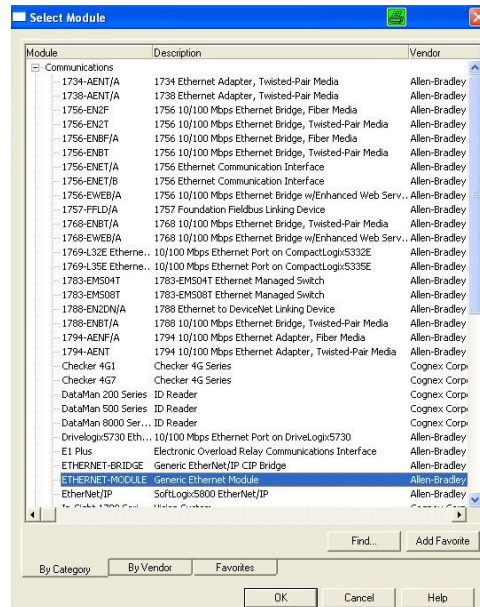

Now enter a user-defined tag name to select the general format Data-SINT, to enter the IP address of the module and to enter the correct connection parameters.

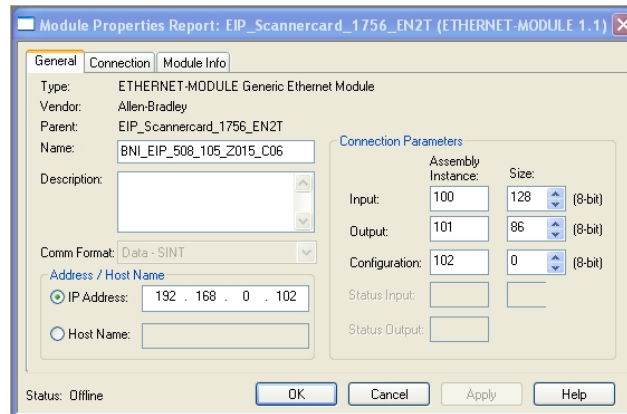

## 5 Integration

The new module and corresponding controller tags are generated automatically.

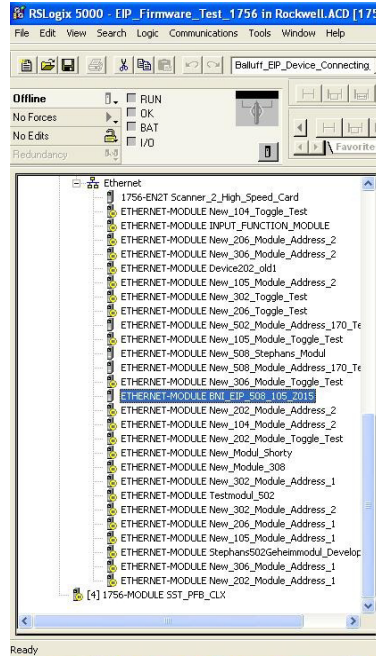

Then download the configuration

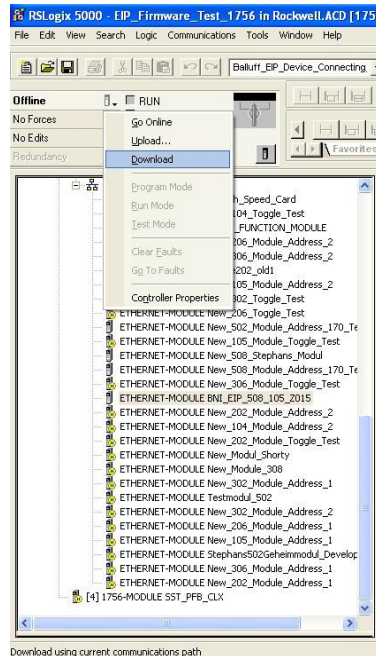

## 5 Integration

When the download is done, you can observe and control the tags using the Controller Tags option. Make sure you select the correct tag name, which you configured beforehand. The input, output and configuration data for this is described on the following pages. You can use these tags for the programming, too.

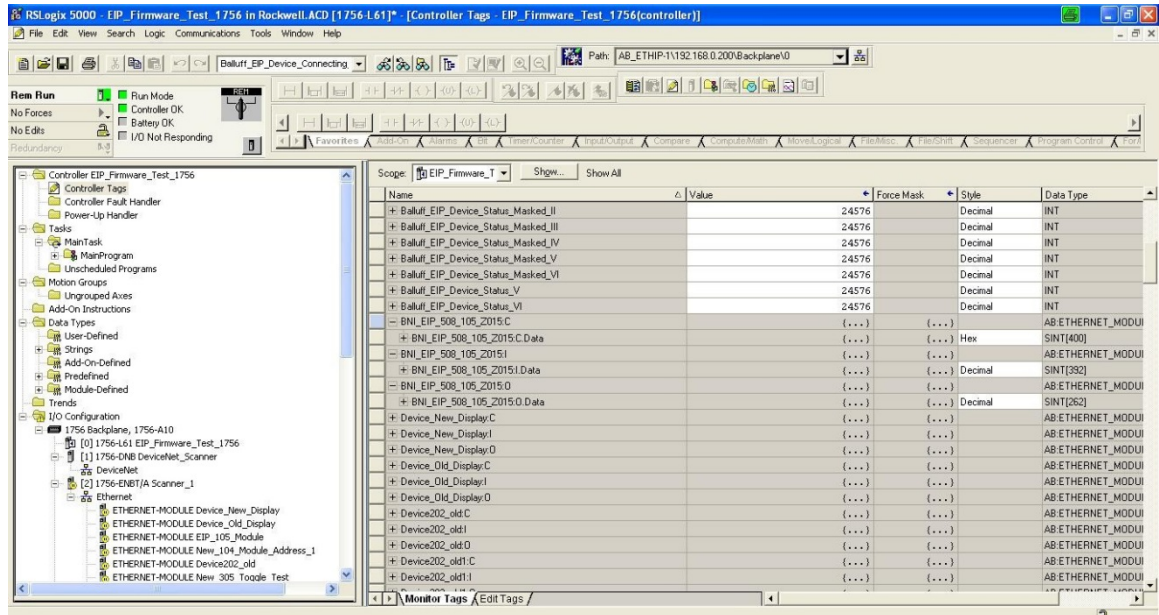

## 5 Integration

### 5.2. Data Configuration

Please enter the following values to your Control System. They describe the data sizes for input, output and configuration data.

	Instance ID	Data length
INPUT	100	128
OUTPUT	101	86
CONFIG	102	0

### 5.3. Configuration Data

The BNI EIP-508-105-Z015-C06 has no configuration assembly.  
The port configuration is fixed as IO-Link and cannot be changed.

#### Module configuration

All IO-Link ports are always activated.

#### IO-Link port configuration

The cycle time is not predefined.  
Validation and parameter server are disabled.

**6 Configuration via Explicit Messages**

**QuickConnect** The QuickConnect function makes it faster to boot up and integrate the BNI EIP-508-105-Z015-C06 module.

Enabling QuickConnect automatically takes over all necessary port properties on the module:

- Static IP address
- Ports at 100 Mbps full-duplex
- Auto-negotiation disabled
- Auto MDI-X disabled
- Prepared for linear topology

You can configure **QuickConnect** via the following class instance attribute of the explicit messages:

Class	Instance	Attribute	Value
245 (0xF5)	1 (0x01)	12 (0x0C)	0: disabled (default) <b>1: enabled</b>

---

**i Note** For QuickConnect to be enabled, ACD (Address Conflict Detection) must also be enabled. This is switched on by default.

---

The **ACD** can be reviewed and changed using the following class instance attributes of the explicit messages:

Class	Instance	Attribute	Value
245 (0xF5)	1 (0x01)	10 (0x0A)	0: disabled <b>1: enabled</b> (default)

Overview of the QuickConnect classes and connection time:

BNI EIP-508-105-Z015-C06 HW 5 SW ≥ 3.2:  
QuickConnect Class B, connection time 1 second

BNI EIP-508-105-Z015-C06 HW 6 SW ≥ 4.2:  
QuickConnect Class B, connection time 450 milliseconds

## 6 Configuration via Explicit Messages

### Rockwell Automation Products that are Compatible with QuickConnect

Component	Supported Rockwell Automation Products
Controller	ControlLogix® controllers: <ul style="list-style-type: none"> <li>• 1756-L6x</li> <li>• 1756-L7x</li> </ul> GuardLogix controllers: <ul style="list-style-type: none"> <li>• 1756-L6xS</li> <li>• 1756-L7xS</li> </ul> All controllers require firmware revision 20.001 or later.
EtherNet/IP managed switch on the controller side	Stratix 6000 switches: <ul style="list-style-type: none"> <li>• 1783-EMS04T</li> <li>• 1783-EMS08T</li> </ul> Stratix 8000 switches: <ul style="list-style-type: none"> <li>• 1783-MS06T or 1783-MS10T</li> <li>• 1783-RMS06T or 1783-RMS10T</li> <li>• 1783-MX08T or 1783-MX08F</li> </ul>
EtherNet/IP communication modules	ControlLogix communication modules: <ul style="list-style-type: none"> <li>• 1756-EN2T with firmware revision 4.003</li> <li>• 1756-ENBT with firmware revision 6.002</li> </ul>
Application logic that uses generic CIP Messages to inhibit and uninhibit I/O modules	Studio 5000 Logix Designer application, version 21.00.00 or later or RSLogix 5000 software, version 20.01.02

Source:  
 Allen-Bradley Ethernet/IP QuickConnect Application Technique  
 Page 13

## 6 Configuration via Explicit Messages

### Example with Rockwell Components

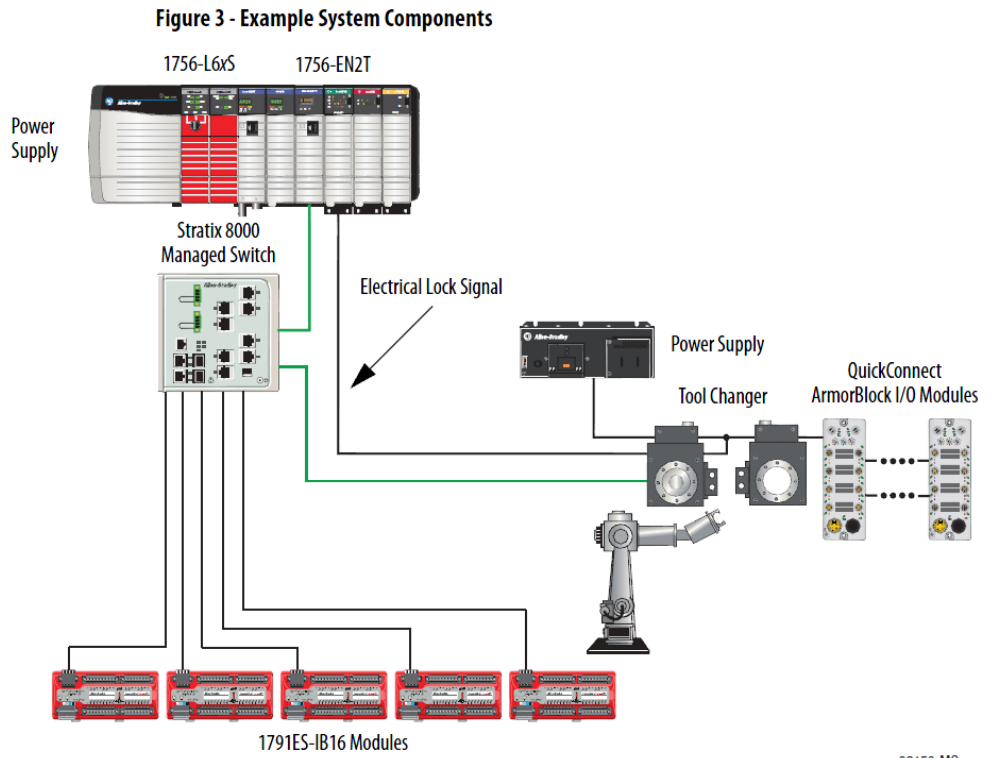

Source:  
Allen-Bradley Ethernet/IP QuickConnect Application Technique, Page 12

Please also note the following:

- Direct connection between PLC and QuickConnect slave with crossover cable
- Slave-to-slave connection using patch cable
- For setting up the topology, only the linear topology with a maximum of 20 modules on the tool side is permitted.
- If needed, only one managed switch may be used between the PLC and Ethernet/IP slave.
- To trigger the QuickConnect sequence, an electrical lock signal is required that reads in the supply voltage of the QuickConnect slaves via the controller.

PLC Program

Add Application Logic

Add ladder logic to inhibit and uninhibit QuickConnect I/O modules:

- Run this logic in a periodic task with a recommended 10 ms update rate.
- The logic examples shown configure two ArmorBlock I/O modules. Modify the code as needed to configure as many as 20 ArmorBlock I/O modules.

**IMPORTANT** A connection time of 500 ms with 20 QuickConnect modules is supported with only a ControlLogix 1756-L7x controller and 1756-EN2T communication module. For average connection times per number of modules, see [Average Timing with Rockwell Automation Products on page 50](#).

Inhibit and Power Down

Add this logic to inhibit and power down the QuickConnect modules.

1. Rung 0: Inhibit the modules.

Before making a tool change, you must uninhibit the QuickConnect ArmorBlock I/O modules mounted to the tool before powering down. Use a GSV (Mode) instruction to monitor the present state of the modules and one SSV (Mode) instruction per module to inhibit the modules.

The input condition to start the inhibit process must come from an external input. For example, as the robot is traveling back to change out the tool, this input condition must be enabled. By the time the tool is being changed, the modules are inhibited and can proceed to powering down the tool and modules.

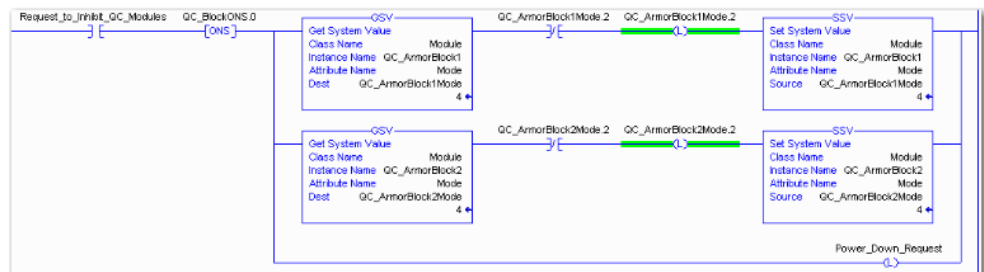

Source: Allen-Bradley Ethernet/IP QuickConnect Application Technique, Page 29

**6 Configuration via Explicit Messages**

2. Rung 1: Verify the modules are inhibited.

After the modules have been inhibited, verify that the modules have indeed been inhibited. Use one GSV (Entry Status) instruction per module. When the Entry Status value equals a decimal value of 24576, the module can be disconnected from the robotic arm and powered down.

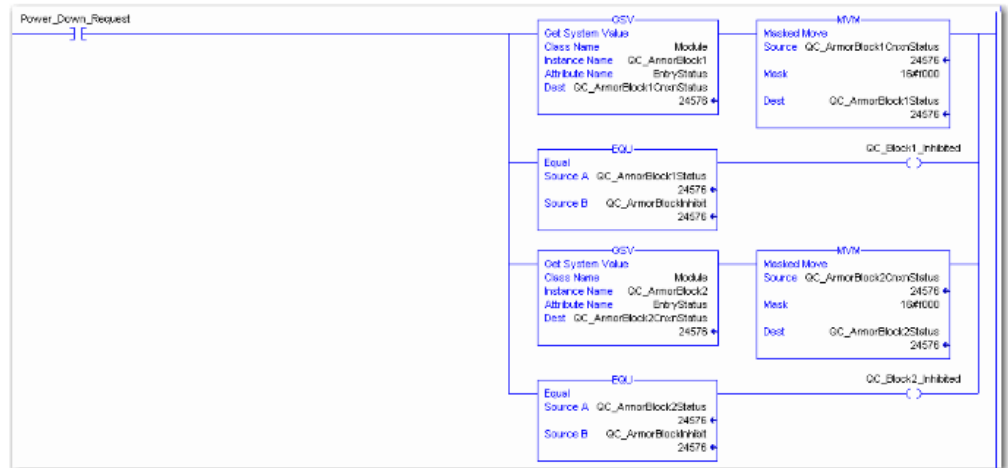

3. Rung 2: Power down the module.

This rung verifies that all the modules have been inhibited and powered down. The tool and modules can be physically disconnected from the robotic arm.



Source:  
Allen-Bradley Ethernet/IP QuickConnect Application Technique, Page 30

### Uninhibit and Power Up

Add this logic to uninhibit and power up the QuickConnect I/O modules.

1. Rung 3: Power up the modules.

Once the tool and module is connected, an external input module sends an electrical lock input signal. On receipt of the signal, start a timer to keep track of how long the tool and modules have been connected.

Every QuickConnect ArmorBlock I/O module has a delay time embedded in its electronic data sheet (EDS) file. This delay time is the amount of time the module takes to power up. The module takes about 300 ms to fully power up before establishing a connection to the controller.

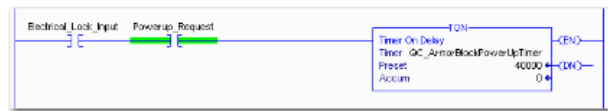

2. Rung 4: Uninhibit the modules.

When the Timer.Acc is greater than or equal to the module delay time (300 ms), use an SSV (Mode) instruction to uninhibit the module. Use a GSV (Mode) instruction to verify the mode of the module at powerup.

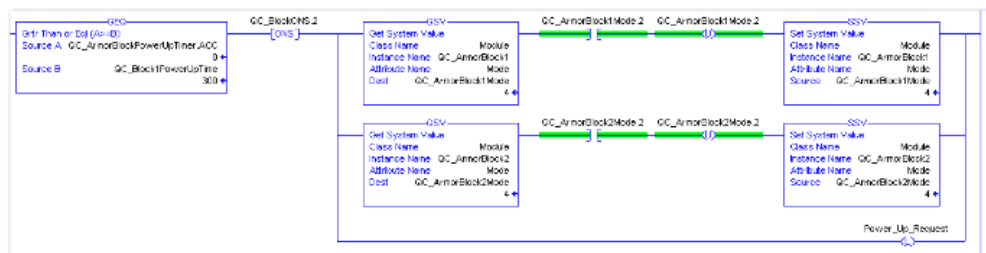

Source: Allen-Bradley Ethernet/IP QuickConnect Application Technique, Page 31

**6 Configuration via Explicit Messages**

3. (Optional) Rung 5: Verify the modules are uninhibited.

After the modules have been uninhibited, verify that the modules have indeed been uninhibited. Use one GSV (Entry Status) instruction per module. When the Entry Status value equals a decimal value of 16384, the module has been uninhibited.

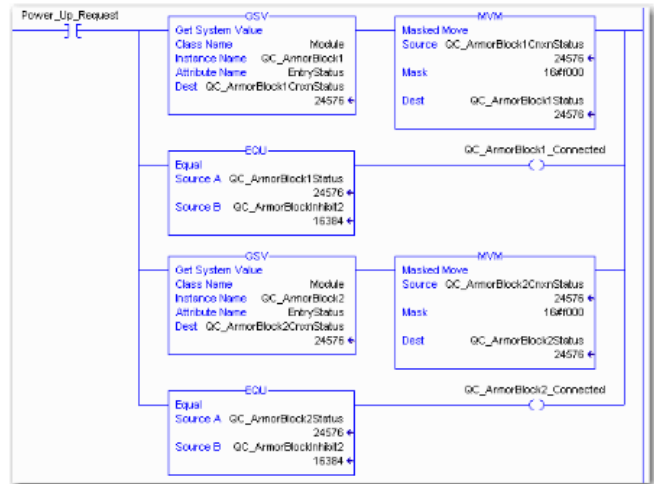

Source:  
Allen-Bradley Ethernet/IP QuickConnect Application Technique, Page 32

**Fault State**

A safe state that the port is to take on in the case of a loss of bus communication can be predefined for each output on the port pins.

The fault state settings can be configured using the following class instance attributes of the explicit messages.

**Enable/Disable Fault State**

Class	Instance	Attribute	Value
9 (0x09)	1 – 16 (corresponds to outputs 0-15)	6	0: Fault state disabled 1: Fault state enabled

**Fault State Action**

Class	Instance	Attribute	Value
9 (0x09)	1 – 16 (corresponds to outputs 0-15)	5	0: Output on 1: Hold last state

**Note**



The fault state settings are stored only temporarily in the module. They are deleted after a power reset.

To ensure a long-term fault state configuration, the configuration has to be programmed via the PLC so that the settings are transferred to the module again when the system is restarted.

## 6 Configuration via Explicit Messages

### IO-Link Device Parameterization

There are two options for configuring an IO-Link device connected to the IO-Link port.

- Configuration via the web server refer to the "Web Server" chapter under "Device Properties"
- Configuration via explicit messages

The following example describes how Rockwell RSLogix 5000 devices can be used to configure an IO-Link device via explicit messages.

For this purpose, the "MSG" components in the PLC program are used.

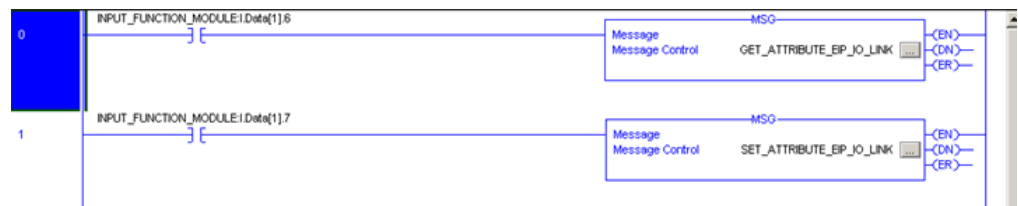

### Read IO-Link Parameter

Service Code	Class	Instance	Attribute
0x32	0x96	1-8 (corresponds to IO-Link ports 1-8)	0x03 (Read Parameter)

Source Length must correspond to at least the read parameters, but a larger value can also be entered. (In this example, 100 bytes)

As the Source Element (Write) and as the Destination Element (Read), create one SINT[100] array each and select the first line[0].

Name	Data Type	Description
_Interface_Object_IO_Link_Param_Read[0]	SINT	
_Interface_Object_IO_Link_Param_Read[1]	SINT	
_Interface_Object_IO_Link_Param_Read[2]	SINT	
_Interface_Object_IO_Link_Param_Read[3]	SINT	
_Interface_Object_IO_Link_Param_Read[4]	SINT	
_Interface_Object_IO_Link_Param_Read[5]	SINT	
_Interface_Object_IO_Link_Param_Read[6]	SINT	
_Interface_Object_IO_Link_Param_Read[7]	SINT	
_Interface_Object_IO_Link_Param_Read[8]	SINT	

6 Configuration via Explicit Messages

In the Source Element Array (Write), enter which index is to be read. In this example, this is index 0x4E.

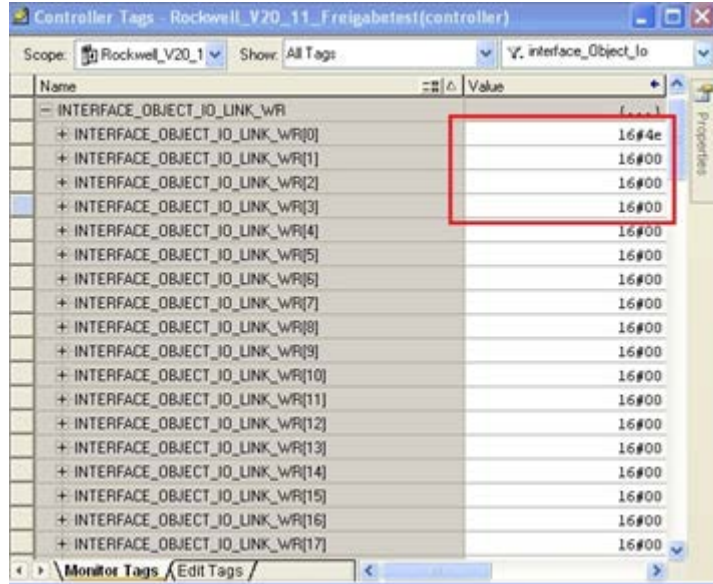

Destination Array (Read) shows the read-out value. In case of a configuration error, the error code is likewise displayed there.

In the "Communication" window, you have to select the Ethernet module on which the configuration is to take place.

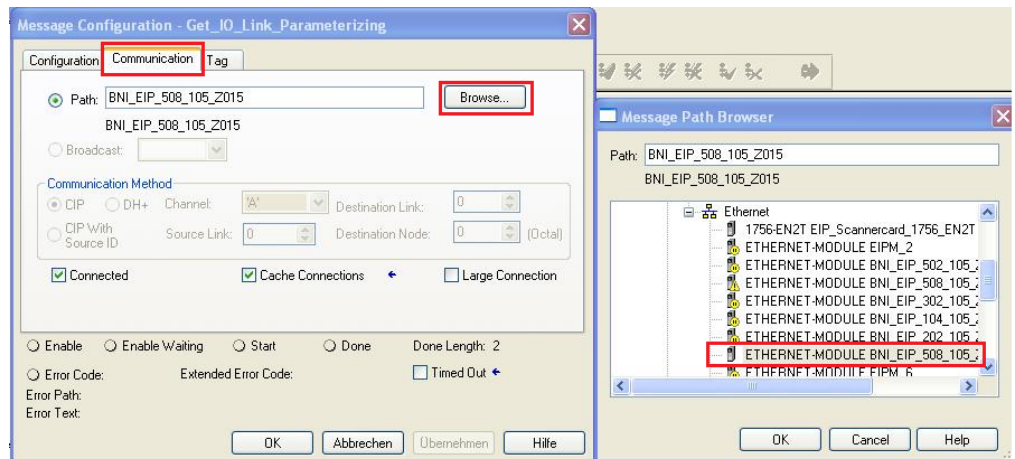

## 6 Configuration via Explicit Messages

### Write IO-Link Parameter

Service Code	Class	Instance	Attribute
0x32	0x96	1-8 (corresponds to IO-Link ports 1-8)	0x02  (Write Parameter)

Source Element and Destination Element are to be selected so they are identical to the previous example, "Read IO-Link parameter".  
The Source Length must be exactly the same length as the parameter data to be written.

In this example, index 0x4E, subindex 0, value 0x02 is written in Source Element Array (Write).  
In case of a configuration error, an error code appears in Destination Element Array (Read).

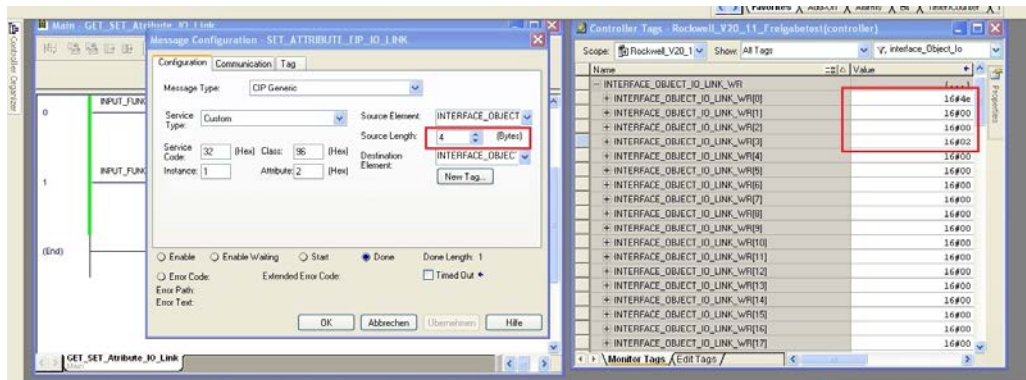

In the "Communication" window, you likewise have to select the Ethernet module on which the configuration is to take place.

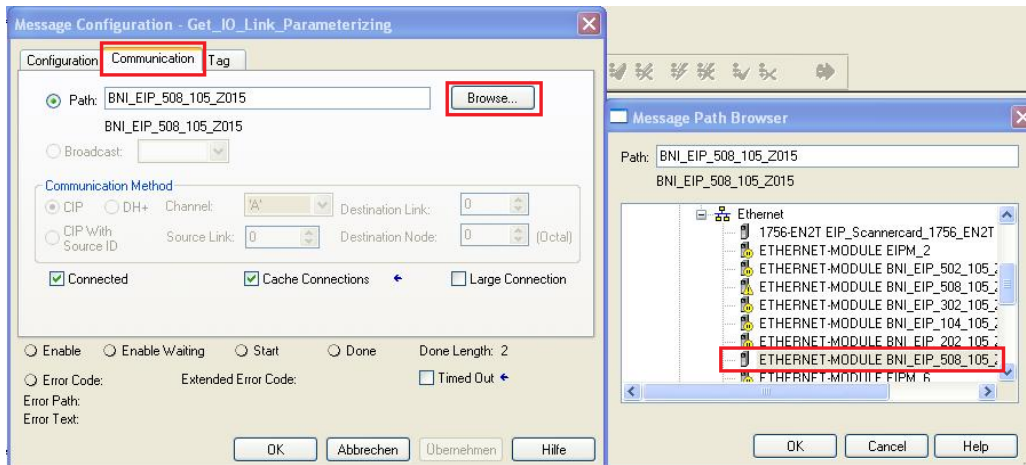

### Note



The explicit messages functions are implemented in accordance with the Volume 1: Common Industrial Protocol Specification and Volume 2: Ethernet/IP Adaption of CIP.

**7 Process Data**

**7.1. Process Data Inputs**

There are 128 bytes of Input data. Have a look at the tables below to see the mapping of the process data inputs.

Byte	Module part	Description
0...7	Standard I/O ports	Process data inputs on standard Inputs
8...22	IO-Link port 0	Process data inputs on IO-Link port 0
23...37	IO-Link port 1	Process data inputs on IO-Link port 1
38...52	IO-Link port 2	Process data inputs on IO-Link port 2
53...67	IO-Link port 3	Process data inputs on IO-Link port 3
68...82	IO-Link port 4	Process data inputs on IO-Link port 4
83...97	IO-Link port 5	Process data inputs on IO-Link port 5
98...112	IO-Link port 6	Process data inputs on IO-Link port 6
113...127	IO-Link port 7	Process data inputs on IO-Link port 7

**Standard Input Data**

Byte	Bit								Description
	7	6	5	4	3	2	1	0	
0	I32	I34	I22	I24	I12	I14	I02	I04	Input data I04 → Input on port 0 pin 4 If a port is configured as an IO-Link port, result is 0.
1	I72	I74	I62	I64	I52	I54	I42	I44	
2	S3		S2		S1		S0		Short circuit status Short circuit between pin 1 and 3 on stated port
3	S7		S6		S5		S4		
4	O32	O34	O22	O24	O12	O14	O02	O04	Overload status O04 → Overload on port 0 pin 4 Only if port is configured as output
5	O72	O74	O62	O64	O52	O54	O42	O44	
6	0	0	0	0	0	NA	PS	PA	Power status NA: No actuator supply PS: Sensor power PA: actor power
7	0	0	0	0	0	0	0	0	Reserved

## 7 Process Data

### IO-Link Input Data

Byte	Bit								Description	
	7	6	5	4	3	2	1	0		
8 ... 22									IO-Link port 0 input data	
23	0	0	0	0	0	0	DC	IOL	IO-Link status <i>IOL: Port in IO-Link mode</i> <i>DC: Device connected</i> <i>0: Reserved</i>	
24	SC	0	0	0	0	PDI	DF	VF	IO-Link error <i>VF: Validation failed</i> <i>SC: IO-Link short-circuit</i> <i>DF: Data storage validation failed</i> <i>PDI: Process data invalid</i>	
25	Mode		Type		0				Event 1	<i>Mode:</i> 0: Reserved 1: Event single shot 2: Event disappears 3: Event appears <i>Type:</i> 0: Reserved 1: Notification 2: Warning 3: Error
26	Event code high									
27	Event code low									
...	The data of the other IO-Link ports are structured identically and described in the following.									

7 Process Data

7.2. Process Data Outputs

There are 86 bytes of output data. Have a look at the tables below to see the mapping of the process data outputs.

Byte	Module part	Description
0...5	Standard I/O ports	Process data outputs on standard Inputs
6...15	IO-Link port 0	Process data outputs on IO-Link port 0
16...25	IO-Link port 1	Process data outputs on IO-Link port 1
26...35	IO-Link port 2	Process data outputs on IO-Link port 2
36...45	IO-Link port 3	Process data outputs on IO-Link port 3
46...55	IO-Link port 4	Process data outputs on IO-Link port 4
56...65	IO-Link port 5	Process data outputs on IO-Link port 5
66...75	IO-Link port 6	Process data outputs on IO-Link port 6
76...85	IO-Link port 7	Process data outputs on IO-Link port 7

Standard Output Data

Byte	Bit								Description
	7	6	5	4	3	2	1	0	
0	O32	O34	O22	O24	O12	O14	O02	O04	Output data O04 → Output on port 0 pin 4 To use this function on a IO-Link port the port must be configured as an output
1	O72	O74	O62	O64	O52	O54	O42	O44	Restart Restart output here after a detected short-circuit
2	R32	R34	R22	R24	R12	R14	R02	R04	Reserved
3	R72	R74	R62	R64	R52	R54	R42	R44	Display Control DL: Display lock / PLC lock GO: Green LED on display on RO: Red LED on display on
4	0	0	0	0	0	0	0	0	
5	0	0	0	0	0	DL	GO	RO	

IO-Link Output Data

Byte	Bit								Description
	7	6	5	4	3	2	1	0	
6...15									IO-Link port 0 output data
...	The data of the other IO-Link ports has the same structure and follows here								

8.1. General

With the implemented display, the address is output directly to the devices BNI EIP...  
The following address types are possible:

- IP address
- Subnet mask
- Gateway address

Each address is composed of 4 octets.

The display also shows information about the hardware and firmware update.

The display has a locking function that can be enabled from the control panel. If the lock is set, no more editing can be done (see bit layout, Chapter 6.2 Standard output data).

8.2. Address Specifications

IP address: 192.168.1.1  
Subnet mask: 255.255.255.0  
Gateway address: 192.168.1.1

8.3. Control and Display

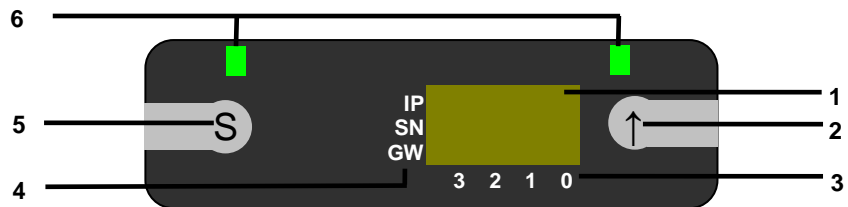

- |                |                       |
|----------------|-----------------------|
| 1 Display      | 4 Address type cursor |
| 2 Arrow key    | 5 "Set" key           |
| 3 Octet cursor | 6 LED                 |

8.4. Display Information

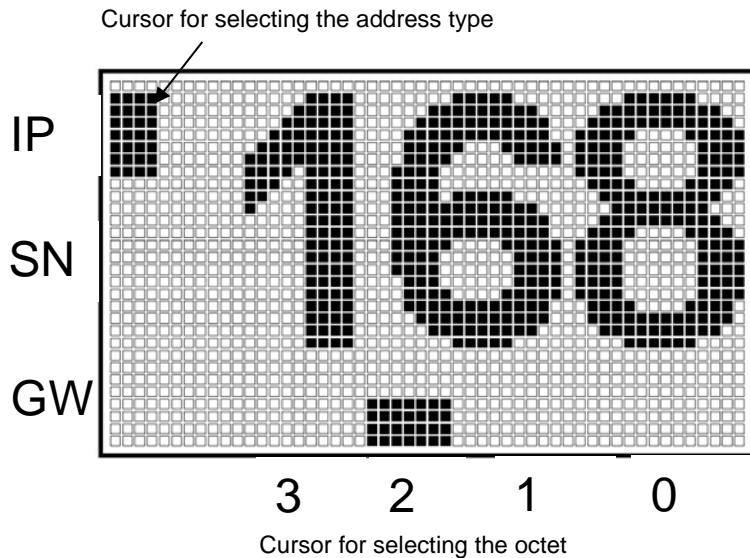

- IP: IP address  
SN: Subnet address  
GW: Gateway address

- 3: First octet  
2: Second octet  
1: Third octet  
0: Fourth octet

8 Display

8.5. Design and Symbols

In the following flow charts, some symbols are used to describe the display functionality:

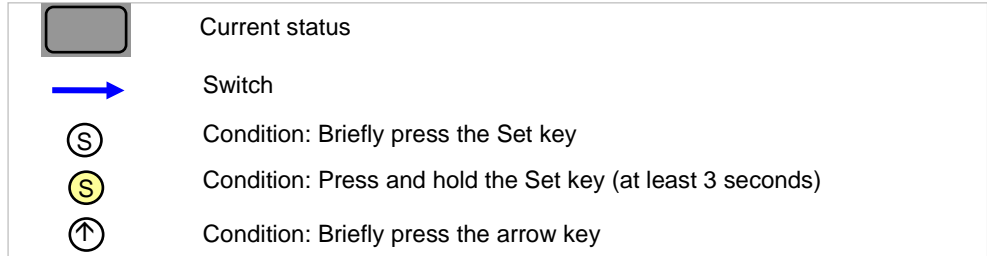

8.6. Startup

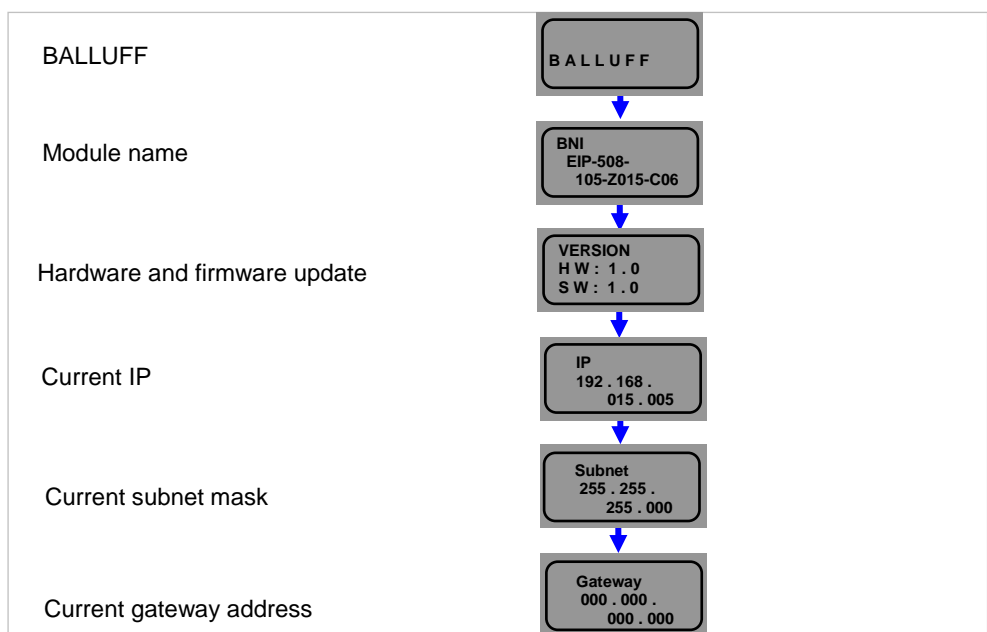

8.7. Main Menu

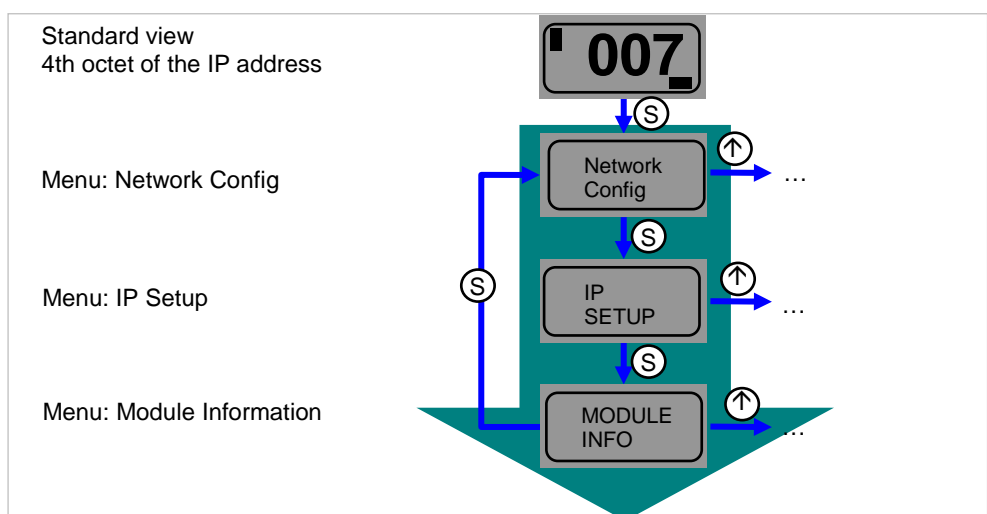

- Press the Set key briefly to scroll through the main menu.
- Press the arrow key to open the menu.



8 Display

8.10. Edit mode

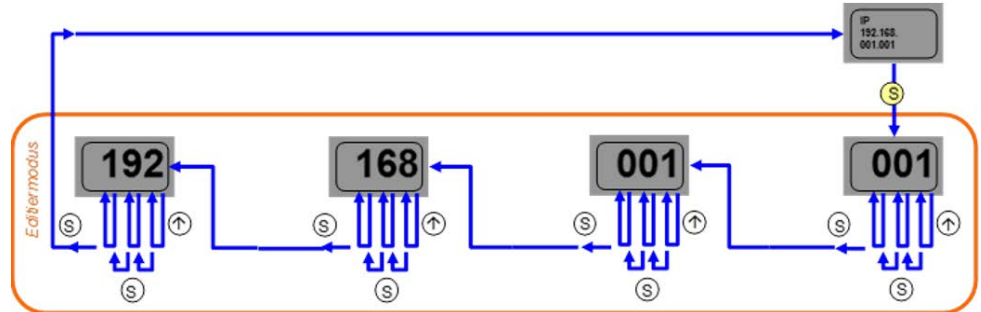

- In the Network Configuration menu, select IP / Subnet or Gateway Address.
- Press the set button long to switch to edit mode.
- Press the arrow key briefly to change the number.
- Press the Set button briefly to move to the next position.
- After the last digit, press the set button briefly to move to the next octet of the address or to accept the new number after the last octet.



**Note**

The module has to be restarted to work with the new configuration.

## 8.11. Module Information

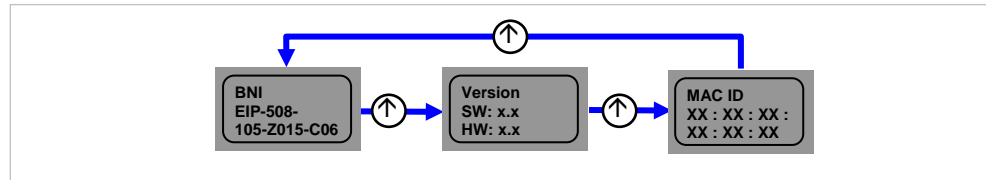

- Briefly pressing the arrow key allows scrolling through the "Module information" menu.
- The product name, module updates and Mac-ID are displayed as information.

## 8.12. General Information

- Press and hold the arrow key to scroll quickly in editing mode.
- If no key is pressed for 10 seconds, the view reverts to the standard display (4th octet of the IP address). Changes that have not been saved will be lost.
- Differences between the new configuration and the configuration with which the module works are indicated by an unequal sign. In this case, the screen switches to the standard display after 5 seconds.
- The display flashes in editing mode. The display flickers in fast scroll mode.
- If the module receives a single ping, the word "Ping" appears on the display for a couple of seconds. Then the previous display returns. You can exit ping mode sooner by briefly pressing the Set key.
- If the module receives two or more pings, the word "Ping" appears on the display. You can exit the display only by briefly pressing the Set key. Then the display before the ping returns.
- The LED function of the display LEDs can be set in a user-specific manner by setting several bits in the process data outputs. (see bit layout, standard output data)
- The plc lock function can also be used by setting a bit in the process data outputs. (see bit layout, standard output data)

**Note**

You cannot select editing mode in the display if the plc lock is set in the process data inputs by a bit (see bit layout, standard output data)

## 9 Web Server

### 9.1. General

The BNI fieldbus module contains an integrated web server for retrieving detailed device information and for configuring the device.

To use the web interface you must first ensure that the module has been correctly integrated into your network. In addition the IP subnet of the BNI module must be accessible from the PC on which the browser is running. Please use Internet Explorer 10 or newer as the browser; older versions may result in display problems.

For open a connection with the web server, enter the IP address of the module in the address line of the browser. The homepage then appears with the essential device information.

The screenshot displays the web interface for the Balluff BNI PNT-508-105-Z015 module. The interface includes a navigation bar with icons for Home, Ports, IODD, Login, Config, Log, and Info. The main content area is titled "Module Information" and lists the following details:

Product Name:	BNI PNT-508-105-Z015
Order Code:	BNI005H
Name:	unknown name
Location:	unknown location
Contact:	unknown contact
Firmware Revision:	3.2
Hardware Revision:	6
Station name:	mydevice
IP Address:	192.168.0.3
Subnet Mask:	255.255.255.0
Gateway Address:	0.0.0.0
MAC Address:	00:19:31:3F:FF:32
Link Speed Port 1:	100 Mbit/s FULL
Link Speed Port 2:	No Link
PLC Lock:	No

To the right of the text is a photograph of the physical module, which features eight RJ45 ports arranged in two columns of four. A legend below the image is partially visible, labeled "> LED Legend".

**9.2. Navigation / Info** The navigation bar is located in the upper area of the window, which allows you to switch between the various dialogs of the web interface. To do this click on the corresponding icon.

When the "Info" tab is selected the following overview appears:

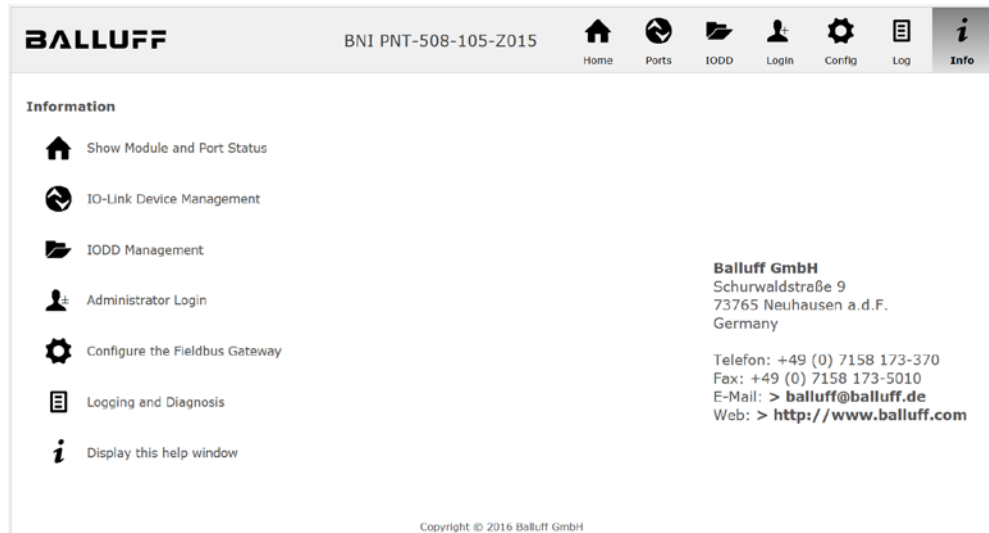

The "BALLUFF" logo at upper right links to the international Balluff homepage.

## 9 Web Server

### 9.3. Login/Logout

To make configuration settings on the fieldbus module using the web interface, you must first log in. Functionalities which cannot be used without logging in are indicated by the grayed out buttons.

The default password is:

BNI PNT-XXX-XXX-XXXX	"BNIPNT"
BNI EIP-XXX-XXX-XXXX	"BNIEIP"
BNI ECT-XXX-XXX-XXXX	"BNIECT"

The password cannot be changed!

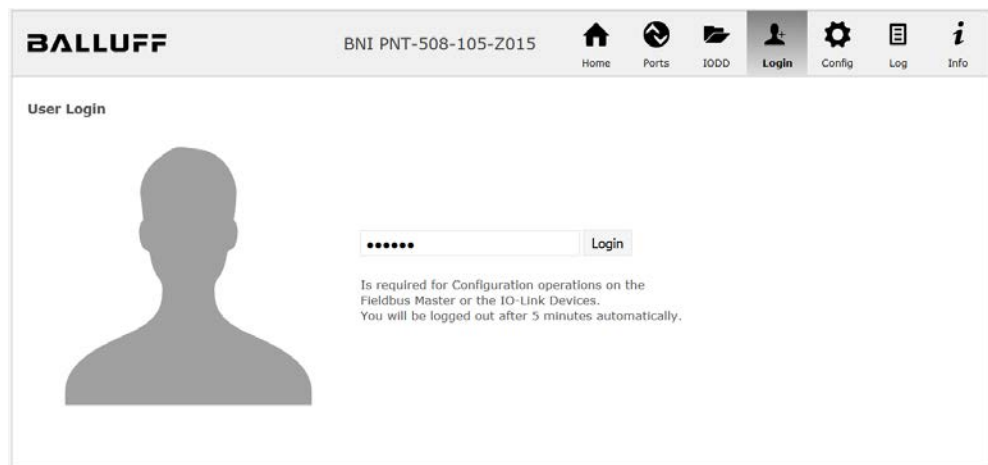

After successfully logging in the dialogs are shown as follows:

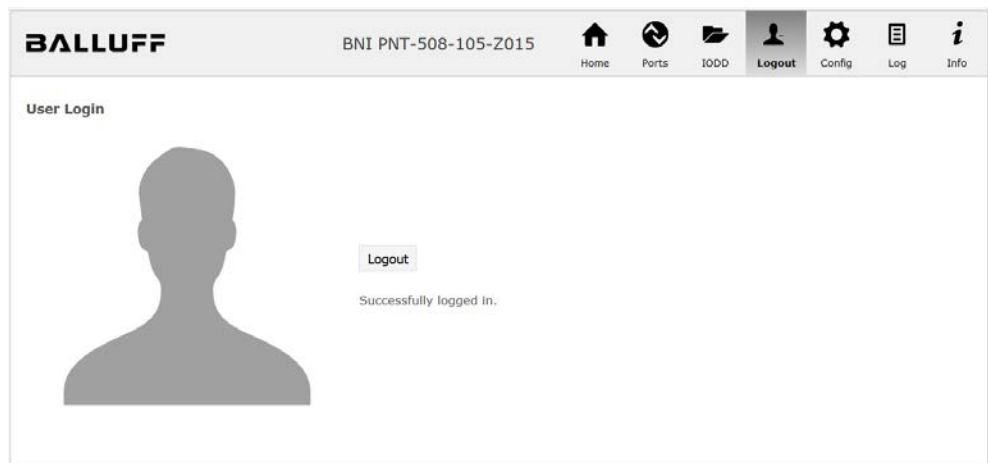

Use the "Logout" button to log out again. After 5 minutes of no interaction with the Webserver the user is automatically logged out.



#### Note

For security reasons the fieldbus module shows only one login at a time with configuration access. Reading (without logging in) is however possible from multiple PCs at the same time on the fieldbus module.

#### 9.4. "Home" dialog

Under "Home" you are given the essential information about the fieldbus itself and its network activity. You are also shown whether the configuration block was enabled by the controller (PLC).

Information is also shown about the current process data and the status of the module via the corresponding LEDs. After selecting "LED Legend" a Help dialog appears which explains the meaning of the LEDs.

If an IO-Link device is connected to one of the configured IO-Link terminals, some of the device data will be displayed in addition to the module data in the form of a link. After selecting one of these links the corresponding device dialog is opened.

The screenshot displays the Balluff web server interface for the BNI PNT-508-105-Z015 module. The interface includes a navigation bar with icons for Home, Ports, IODD, Logout, Config, Log, and Info. The main content area is divided into two sections: Module Information and a terminal status diagram.

**Module Information**

Product Name:	BNI PNT-508-105-Z015
Order Code:	BNI005H
Name:	Balluff GmbH
Location:	Schurwaldstraße 9
Contact:	+49 (0) 7158 173
Firmware Revision:	3.2
Hardware Revision:	6
Station name:	mydevice
IP Address:	192.168.0.3
Subnet Mask:	255.255.255.0
Gateway Address:	0.0.0.0
MAC Address:	00:19:31:3F:FF:32
Link Speed Port 1:	100 Mbit/s FULL
Link Speed Port 2:	No Link
PLC Lock:	No

The terminal status diagram shows a vertical stack of four IO-Link terminals. The top two terminals are labeled with links to device information: **BALLUFF BNI IOL-302-002-Z046** and **BALLUFF BNI IOL-802-000-Z036**. Below the diagram is a link labeled **> LED Legend**.

9 Web Server

PNT:

**Module LED Functions**

LED	Color	Function
US	Green	OK
UA	Green	OK
SF	Red	Signal service
BF	Red	Signal exchange
100	Yellow	100 Mbit/s
LK	Green	Link activity

**Port LED Functions**

IO	0	1
IO-Link	Green	Red
IO-Link	Green	Green
IO-Link	Red	Red

EIP:

**Module LED Functions**

LED	Color	Function
US	Green	OK
UA	Green	OK
Mod	Red	Modbus error
Net	Green	No data exchange
100	Yellow	100 Mbit/s
LK	Green	Link activity

**Port LED Functions**

IO	0	1
IO-Link	Green	Red
IO-Link	Green	Green
IO-Link	Red	Red

9.5. "Ports" dialog

The "Ports" dialog displays information and process data for the connected IO-Link devices. Select the desired IO-Link Port in the image of the fieldbus module on the right side to see the device data.



**Note**

The IO-Link device data are only displayed if the port is also configured as an IO-Link port!

**No appropriate IODD uploaded**

It is possible to read and write the configuration parameters of the IO-Link device via the "Parameters" option. The parameter indexes and subindexes of the IO-Link device are described in the corresponding separate user's guide (and follow the IO-Link conventions).

Under "Events" you can see whether a diagnostic event from the IO-Link device exists.

Under "Parameter Server Content" you can view the content of the parameter server if parameter data is stored on the parameter server.

**BALLUFF** BNI PNT-508-105-Z015 Home Ports IODD Logout Config Log Info

**IO-Link Device Properties (Port 0)**

**Identification Data**

Vendor ID:  
 Device ID: 0x050D20  
 Vendor Name: BALLUFF  
 Vendor Text: www.balluff.com  
 Product Name: BNI IOL-302-002-Z046  
 Product ID: BNI00AU  
 Product Text: Sensor/Actor hub M8  
 Serial Number: 7A 69 68 67 6A 68 73 6C 66 61 6A 6B F6 64 6C 75  
 Hardware Revision: 1  
 Firmware Revision: 1.0 2016/03/08 09:05:24 R2920  
 Application specific tag:

**Process Data**

Inputs (hex): 20 00  
 Outputs (hex): 00 00

**Parameters**

Index:   
 Subindex:   
 Data (hex):   
 Result:  Read  Write

**Events**

Current Event: Secondary supply voltage fault (Port Class B) - Check tolerance

**Parameter server content**

Vendor ID (hex): 00 00  
 Device ID (hex): 00 00 00  
 Checksum (hex): 00 00 00 00  
 Content (hex): (none)

"Ports" dialog with direct parameter access

9 Web Server

**Appropriate IODD uploaded**

If an IODD appropriate to the IO-Link device connected to the currently selected port has been uploaded (see "Dialog "IODD"), the normal dialog for "Process Data" and "Parameters" is not displayed, but rather an expanded dialog. Information from the IODD of the device is used so that the data can be better understood.

Thus in the following screenshot not only are the input data of the distance sensor displayed as a hex number, but also interpreted and labeled under "Input". Since the sensor has no parameters, none are displayed.

**BALLUFF** BNI PNT-508-105-Z015

Home Ports IODD Logout Config Log Info

**IO-Link Device Properties (Port 2)**

**Identification Data**

Vendor ID: 0x0378  
 Device ID: 0x020101  
 Vendor Name: BALLUFF  
 Vendor Text: www.balluff.com  
 Product Name: BAW M18MI-BLC50B-S04G  
 Product ID: 153938  
 Product Text: Inductive distance sensor, 1...5mm  
 Serial Number:  
 Hardware Revision: 1.00  
 Firmware Revision: 1.01  
 Application specific tag:

**Process Data**

Inputs (hex): 00 03 FF  
 Outputs (hex): no outputs

**Input**

Distance absolute	1023
Reserved bits	0

**Events**

Current Event: no Event

**Parameter server content**

Vendor ID (hex): 00 00  
 Device ID (hex): 00 00 00  
 Checksum (hex): 00 00 00 00  
 Content (hex): (none)

Dialog "Ports": IODD interpretation and device image

If the IO-Link device on the currently selected port has parameters, these are shown in table format (see following screenshot). In this example the parameters for the Balluff Smart Light are shown.

The Smart Light is a signal light which can be used in three different modes. These modes can be set using an IO-Link parameter. The parameter values and associated texts are stored in the IO-Link.

This means "Operation Mode" can be read out and displayed ("Read" and "Read All" buttons) or written to the device ("Write" button).

If subindexes have no buttons they cannot be individually processed but rather only the entire index at once.



**Note**

Each changed value must be individually written by clicking on the "Write" button!

Parameters				Read All
64 (0)	Operating mode (rw)	Segment mode ▾	Write	Read
65 (0)	Number of segments (rw)	One segment ▾	Write	Read
66 (0)	Type of level indicator (rw)	Bottom-up ▾	Write	Read
67 (0)	Resolution of level indicator (rw)	8 bit ▾	Write	Read
68 (0)	Level mode, segment 1 (rw)	See child elements		
68 (1)	Level mode, segment 1 color	Off ▾	Write	Read
68 (2)	Level mode, segment 1 dominance	<input checked="" type="radio"/> Color is not dominant <input type="radio"/> Color is dominant	Write	Read
69 (0)	Level mode, segment 2 (rw)	See child elements		
69 (1)	Level mode, segment 2 color	Off ▾	Write	Read
69 (2)	Level mode, segment 2 dominance	<input checked="" type="radio"/> Color is not dominant <input type="radio"/> Color is dominant	Write	Read
70 (0)	Level mode, segment 3 (rw)	See child elements		
70 (1)	Level mode, segment 3 color	Off ▾	Write	Read
70 (2)	Level mode, segment 3 dominance	<input checked="" type="radio"/> Color is not dominant <input type="radio"/> Color is dominant	Write	Read
71 (0)	Level mode, segment 4 (rw)	See child elements		
71 (1)	Level mode, segment 4 color	Off ▾	Write	Read
71 (2)	Level mode, segment 4 dominance	<input checked="" type="radio"/> Color is not dominant <input type="radio"/> Color is dominant	Write	Read

"Ports" dialog: Parameter list of an IO-Link device with uploaded IO-Link

9.6. "IODD" dialog

Using this dialog you can transfer IODDs (device description files for IO-Link devices) and the associated device images to the fieldbus module, so that a detailed representation of the connected IO-Link devices in the "Ports" dialog is possible.

When IO-Link devices are connected and IO-Link ports are activated, the dialog shows a table with information about the IO-Link devices.

The fieldbus module file system supports only device names in "8+3" format, i.e. with a restricted name length. Since IODD files are generally published with a long file name, these must be renamed and given a shorter naming scheme on the PC before uploading to the fieldbus module.

For this a help setting is provided in the dialog, with the associated required IODD file name for the currently connected IO-Link devices shown in the bottom section of the list (column IODD Filename).

Image files without IODD can also be uploaded; the images are still displayed in the "Ports" dialog.

**IODD Management**

Device	Picture	
BA050A01.xml	X	Delete
BA020101.xml	X	Delete
BA050D20.xml	X	Delete

Choose the IODD to upload:

BA020101.png

**Information**

This module has a FAT12 file system, which means it supports only file names in 8.3 convention. **Please rename your IODDs according to the suggested filename in the table below.**

The suggested filename is generated according to following rule:

- The first two characters of the file name are the first two letters of the IODD Vendor Name. If the device has no vendor name, those characters are substituted by underscores.
- The remaining 6 characters must encode the DeviceID in hexadecimal representation (padded with zeros if necessary).

Note that the filename must contain the DeviceID that is in the IODD file!

**Currently connected IO - Link Devices:**

Vendor Name	Product Name	Product ID	Vendor ID	Device ID	IODD Filename
BALLUFF	BNI IOL-302-002-Z046	BNI00AU	0000	050D20	BA050D20.xml
BALLUFF	BNI IOL-802-000-Z036	BNI0072	0378	050A01	BA050A01.xml
BALLUFF	BAW M18MI-BLC50B-S04G	153938	0378	020101	BA020101.xml

Using the "Delete" button you can delete IODDs and device images from the fieldbus when needed.

---

**Note**  
 Before selecting the IODD it must be renamed on the PC to the file name which is shown in the table in the "IODD Filename" column!

---

9.7. "Config" dialog

The configuration page enables configuration of the module. You can change both the module information texts and the port configuration. The "Set Ports" action is not permanently stored in the device and is lost after the next reboot or reset.

PNT / ECT:



EIP:

The screenshot displays the web interface for the Balluff BNI EIP-508-105-Z015 module. The interface is divided into two main sections: "Module Configuration" on the left and "Port Configuration" on the right. The "Module Configuration" section includes fields for Name, Location, and Contact, as well as options for DHCP Client or Static IP. The "Port Configuration" section shows a central image of the module with dropdown menus for selecting the mode (IO Link or Digital Input/Output) for each of the four ports. The interface also features a navigation bar at the top with icons for Home, Ports, IODD, Logout, Config, Log, and Info.

The parameter set "Module Configuration" on the left side is used by clicking "Save Configuration" and permanently stored in the device.

The "Reboot" button reboots the device as if the power to the module had been turned off and on again.

Clicking on "Factory Reset" deletes the configuration and log files saved in the device and then performs a reboot, so that the device is restored to the default factory configuration as on delivery.

9.8. "Log" dialog

This dialog provides general service information about the device as well as a logging function.

The upper table (see screenshot below) contains important information for all service inquiries.



**Note**

If you have a detailed question about a specific situation, send us a screenshot of this Website or print the site as a PDF.

Logging shows events which have occurred in chronological order. This provides a tool for detailed troubleshooting in equipment.

The screenshot shows the BALLUFF web interface for device BNI PNT-508-105-Z015. The top navigation bar includes Home, Ports, IODD, Logout, Config, Log, and Info. The 'Information' section displays the following data:

Product name:	BNI PNT-508-105-Z015	Browser time:	2016-12-16 10:26:29.495
Firmware revision:	3.2	System uptime:	50 secs 291 msecs
MAC address:	00:19:31:3F:FF:02	Free flash space:	1720 KB
IP address:	192.168.0.10	Web version:	2.0.113
Browser version:	Firefox 50.0		

The 'Log' section includes buttons for 'Set module time', 'Clear Log', and 'Update Log'. Below is a table of log entries:

No.	Severity	Date	Origin	Message
0	Notice	2000-01-01 00:00:00.404	SYS	System startup (Oct 6 2016, 11:54:01)
1	Notice	2000-01-01 00:00:00.437	SYS	Set MAC address: 00:19:31:3F:FF:02
2	Notice	2000-01-01 00:00:00.493	IOL_MASTER	IO-Link Master started
3	Informational	2000-01-01 00:00:00.501	IOL_MASTER	FW version 1.2.8
4	Notice	2000-01-01 00:00:01.999	ETH	Port 1: Link Up (100 MBit/s, full duplex)
5	Notice	2000-01-01 00:00:37.926	WEB_IF	Login successful, IP address: 192.168.0.50
6	Error	2000-01-01 00:00:41.902	IOL_MASTER	Port 0: Device disconnected
7	Error	2000-01-01 00:00:42.272	IOL_MASTER	Port 1: Device disconnected
8	Error	2000-01-01 00:00:42.981	IOL_MASTER	Port 3: Device disconnected
9	Notice	2000-01-01 00:00:43.169	IOL_MASTER	Port 2: ISDU read error: Error code 80 Additional Code 11
10	Notice	2000-01-01 00:00:43.347	IOL_MASTER	Port 2: ISDU read error: Error code 80 Additional Code 11
11	Warning	2000-01-01 00:00:43.347	IOL_MASTER	Port 2: BNI IOL-101-S01-K010 connected
12	Notice	2000-01-01 00:00:44.145	IOL_MASTER	Port 4: ISDU read error: Error code 80 Additional Code 11
13	Error	2000-01-01 00:00:44.183	IOL_MASTER	Port 5: Device disconnected
14	Warning	2000-01-01 00:00:44.499	IOL_MASTER	Port 4: BNI IOL-801-000-Z036 connected
15	Error	2000-01-01 00:00:44.830	IOL_MASTER	Port 6: Device disconnected
16	Error	2000-01-01 00:00:45.200	IOL_MASTER	Port 7: Device disconnected

Events are classified using the "**Severity**" column:

**Internal Error** (Emergency, Alert, Critical)

→ The fieldbus module has detected a fault in itself (hardware or software) which should not occur during normal operation. If this happens, the module must be serviced or replaced.

**External Error** (Error, Warning)

→ The fieldbus module has detected what may be a non-permissible event which is affecting the module from the outside. The system may require troubleshooting.

**Event** (Informational, Notice)

The fieldbus module has detected an important normal operating event and reports it. These may include for example configuration actions over the web interface and other configuration interfaces which are also recorded.

Clicking on "Set Module Time" sends the current browser time to the fieldbus module but does not permanently store it. After a reset, reboot or loss of power the time begins to run again from the year 2000.

Clicking on "Update Log" refreshes the display, and "Clear Log" deletes all entries. The log entries are stored in a ring buffer.

## 10 Appendix

### 10.1. Included in the Scope of Delivery

The BNI EIP comprises the following elements:

- IO-Link block
- 4x M12 dummy plugs
- Ground strap
- M4x6 screw
- 20 labels

### 10.2. Order Number

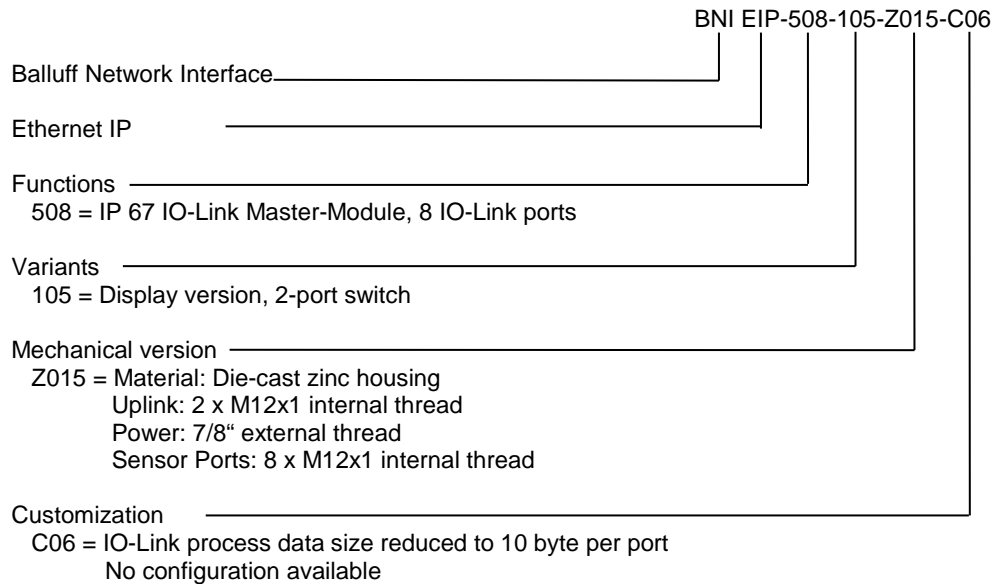

### 10.3. Ordering Information

Product ordering code	Order code
BNI EIP-508-105-Z015-C06	BNI007C

**Notes**

[www.balluff.com](http://www.balluff.com)

Balluff GmbH  
Schurwaldstrasse 9  
D-73765 Neuhausen a.d.F.  
Germany  
Phone +49 7158 173-0  
Fax +49 7158 5010  
[balluff@balluff.de](mailto:balluff@balluff.de)

No. 898159-726 EN • 04.125253 • Edition K17 • Replaces Edition G17 • Subject to modification