

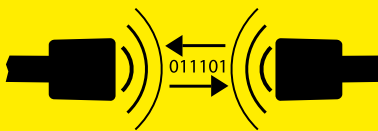

BALLUFF

sensors worldwide

BIC Inductive Couplers

Non-contact power and data transmission in automation



 **IO-Link**

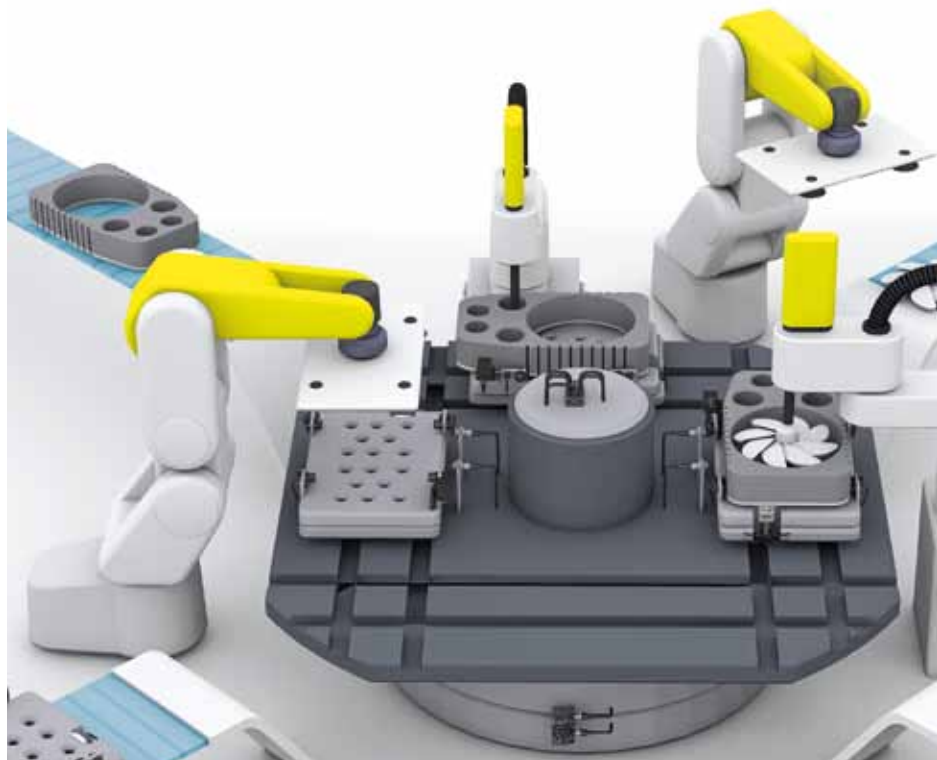



With more than 90 years of company history behind it, Balluff GmbH is a globally leading sensor specialist and system provider. The full-range product line encompasses high-quality sensors and systems for distance measurement and identification, sensors for object detection and fluid measurement as well as top-of-the-line network and connection technology. The global player has a strong presence at 56 locations on all continents. The company headquarters in Neuhausen auf den Fildern are in direct proximity to Stuttgart.

Balluff is synonymous with application-specific customer solutions, comprehensive services, individual consultation and prompt service. Our 2,450 employees worldwide are committed to ensuring that we live up to this reputation.



Flexible transmission of power and data

Inductive couplers for non-contact communication

Fixed wiring of sensors and actuators has disadvantages. Cables and contacts are often subject to heavy strain in automation. Cables can wear out and break, leading to machine downtime.

BIC inductive couplers offer a solution. They transfer signals and power contact-free over an air gap.

The quick-disconnect units are easy to use and require no maintenance, enabling you to meet new demands quickly. Mechanical wear is a thing of the past. This increases system availability, reduces cycle time and enhances the flexibility of workflow processes.

Please see the following applications to learn more about efficient use of BIC inductive couplers. These applications are real life examples, that reveal the many areas in which BIC inductive couplers prove their worth.



| | |
|--|----|
| Flexible transmission of power and data | 3 |
| Throughout the production process | 4 |
| Press shop and die change | 6 |
| Production at the rotary table | 8 |
| Pallets and workpiece carriers | 10 |
| End of arm tool change on robots | 12 |
| Principle of operation | 14 |
| Product overview | 15 |
| Continuous communication with IO-Link | 19 |
| Inductive couplers offer IO-Link functionality | 19 |



Throughout the production process

Reliable non-contact transmission of power and data

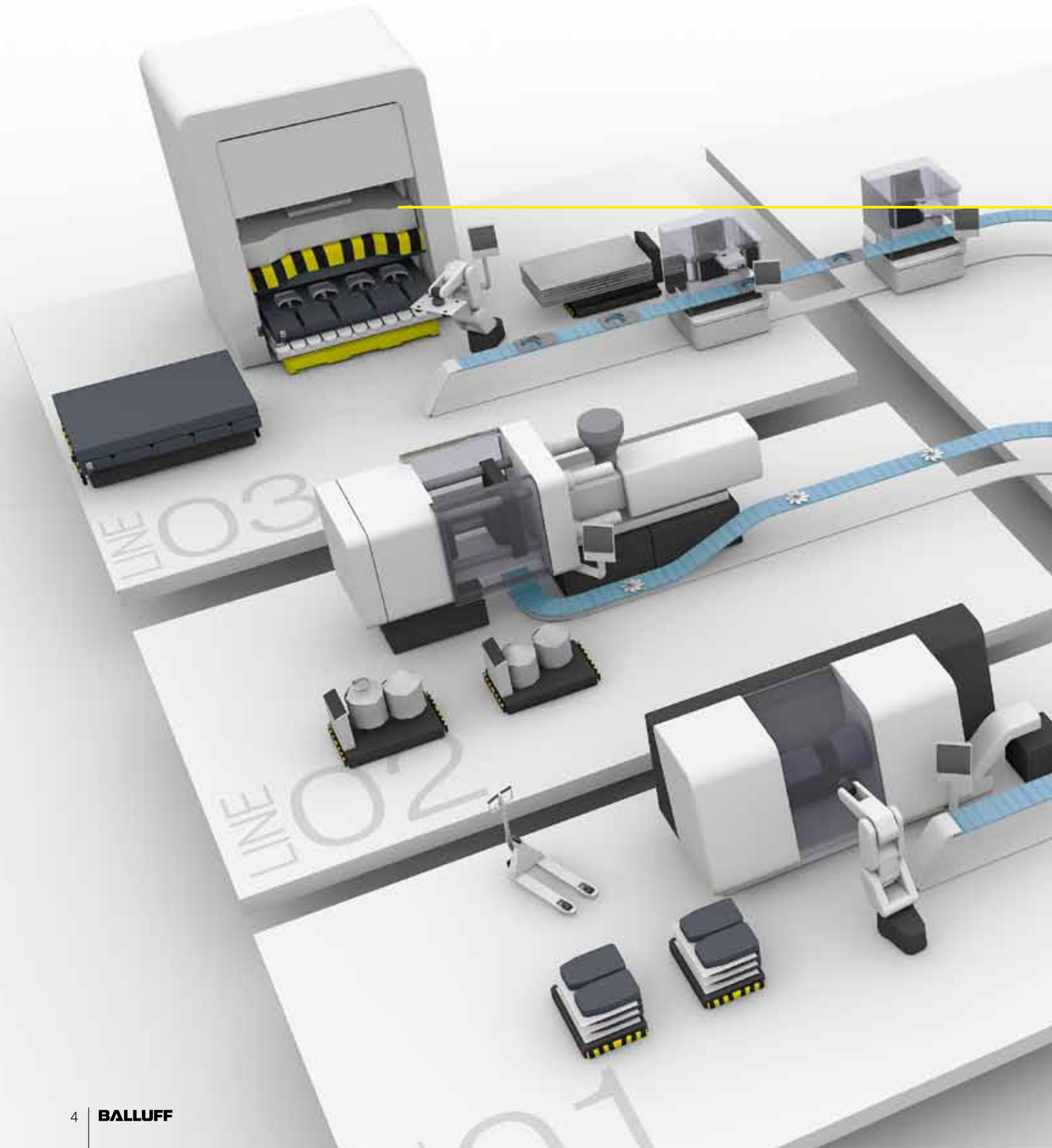

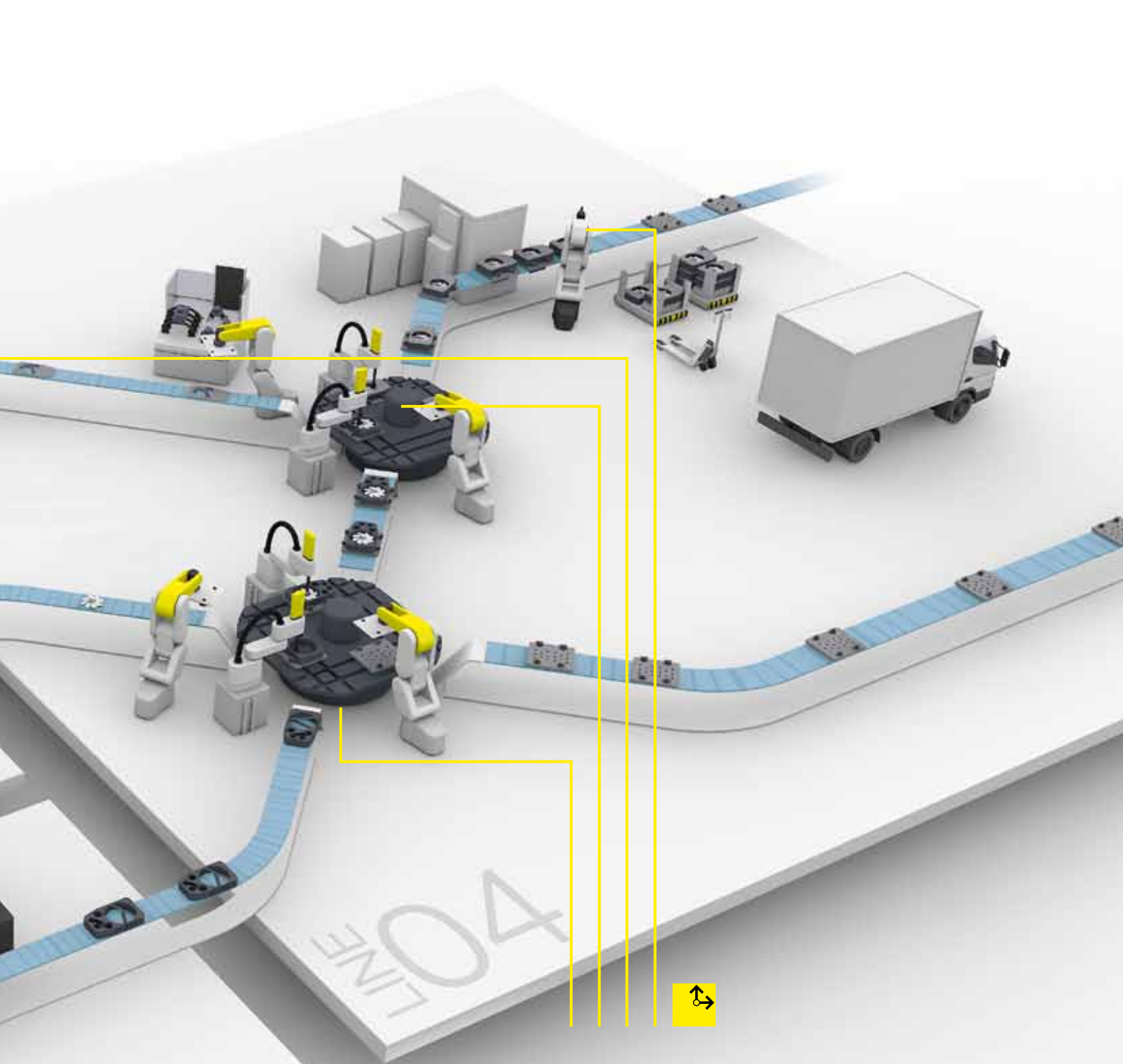

Balluff inductive couplers reduce the sources of error from the loss of communication throughout the entire production process: in classic machine centers, presses, on rotary index tables in assembly, on workpiece carriers or in robotics. Whenever data needs to be transferred to and from moving machine parts, you are on the safe side with Balluff BIC inductive couplers.



Press shop

Automatically changing and securely identifying tools

In die sensors attached to tools on the press detect the alignment of the material and help with die protection. These positioning signals from the sensors are reliably transmitted over a BIC inductive coupler.

Inductive couplers enable automatic tool changing because manual plug-in of mechanical connectors is no longer necessary. In conjunction with a network interface, tools can be identified, allowing for automatic press configuration like shut height values by storing the value with the tool.

In addition, on transfer rail change parts, power and signal can be reliably coupled and changed with the tool.





The inductive coupling system serves as a contact-free connection between the press and the tool. Typically the base is mounted in the bolster of the press in a common area.

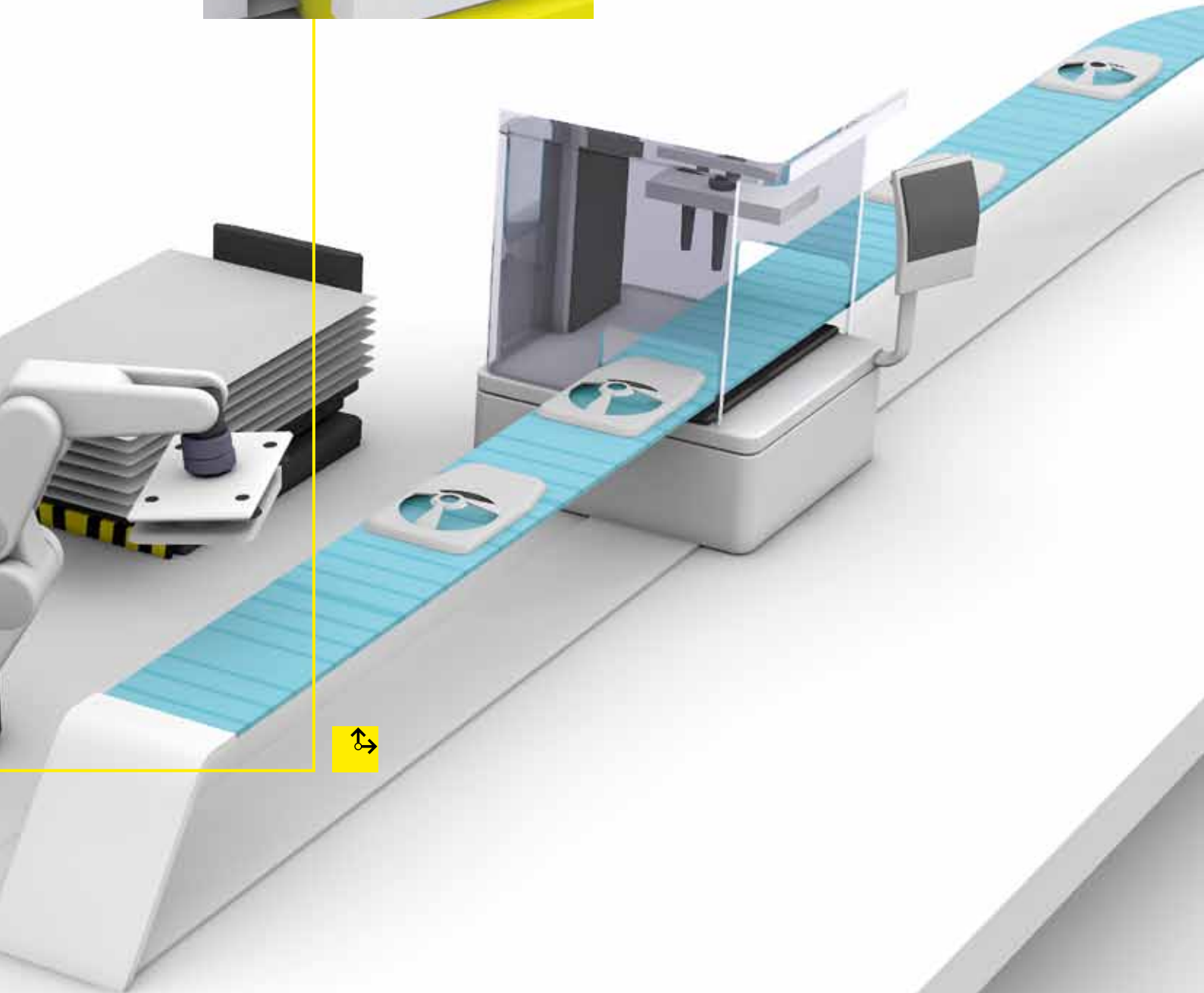



Production at the rotary table

Entirely without slip rings

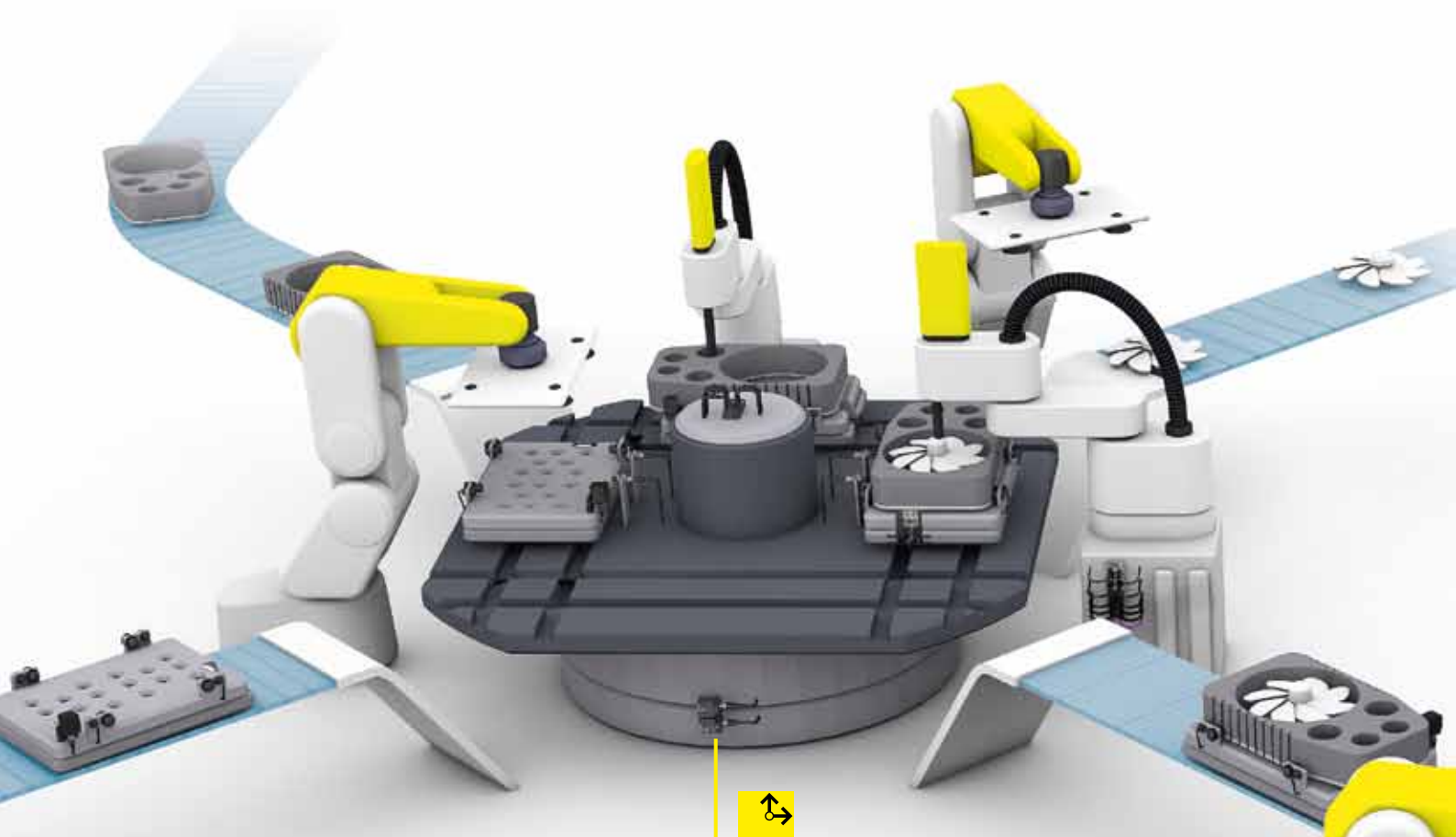

Radial transmission

In the case of radial transmission, the BIC system is mounted in such a way that the base and remote components align during the index positions of the rotary table.

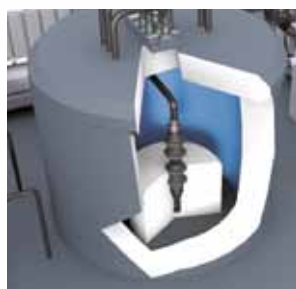

Axial transmission

In the case of axial transmission, the BIC system is located in the central axis of the rotary index table. Communication takes place continuously, independent of the position of the table.

On the rotary index table, data is transmitted from rotating to stationary machine parts. Classic carriers such as slip rings are subject to heavy mechanical wear and repair. This wear leads to malfunctions and expensive standstills.

This can be avoided with wireless BIC systems. The inductive couplers transmit data and power for sensors and actuators without contact. Slip rings on the rotary table are now a thing of the past.

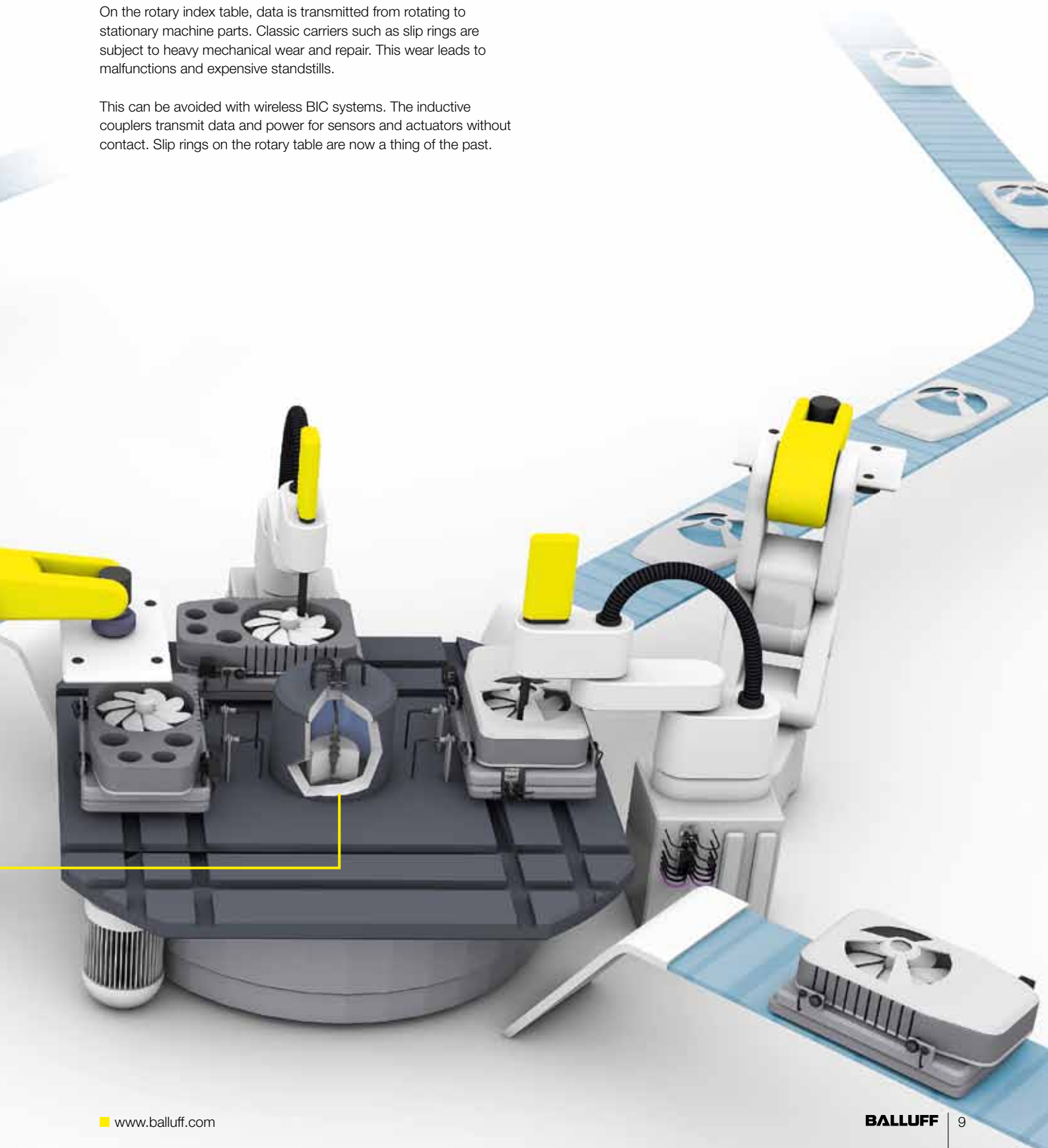



Pallets and workpiece carriers

Immediate contact – reliable speed

Sensors are mounted on pallets that convey components from processing station to processing station. They check the correct alignment of the components and monitor the position of the clamping units. The non-contact BIC inductive coupling system is responsible for supplying the power to the sensors and transmitting the sensor signals to the control system.

Communication is established at each station as soon as the base and remote align. A mechanical connection is no longer necessary.

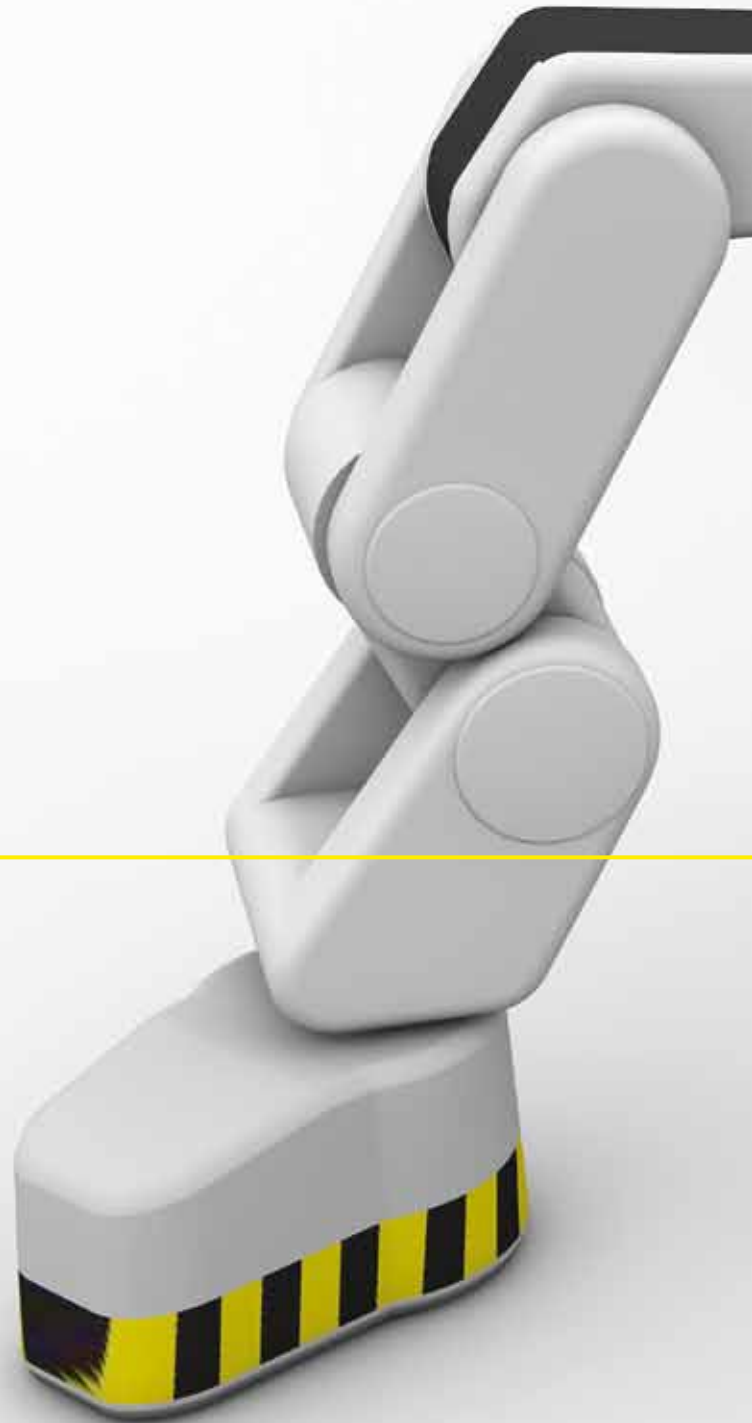

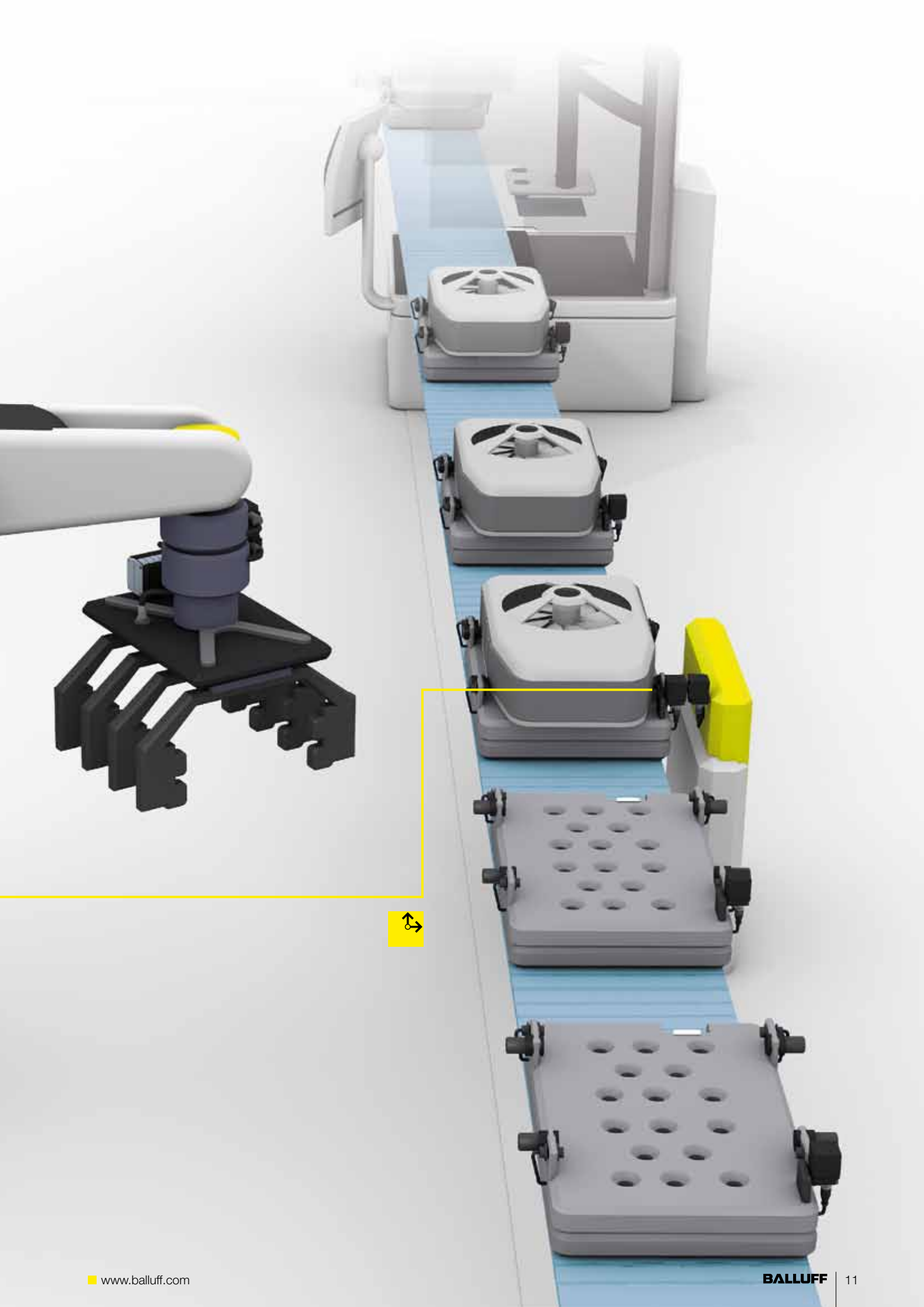



Gripper changing on robots

Fast tool changing – clear allocation of tools

Fast format changes are important for high productivity. However, plugs make it difficult to change grippers on robots.

BIC inductive couplers render mechanical connectors unnecessary. They transmit signals contact-free over an air gap. This ensures freedom from wear, guarantees tools are changed quickly and provides a large degree of flexibility. A further benefit:

The unique identity of the tool can be ensured through an ID stored in the sensor/actuator hub. This excludes the possibility of incorrect allocation.

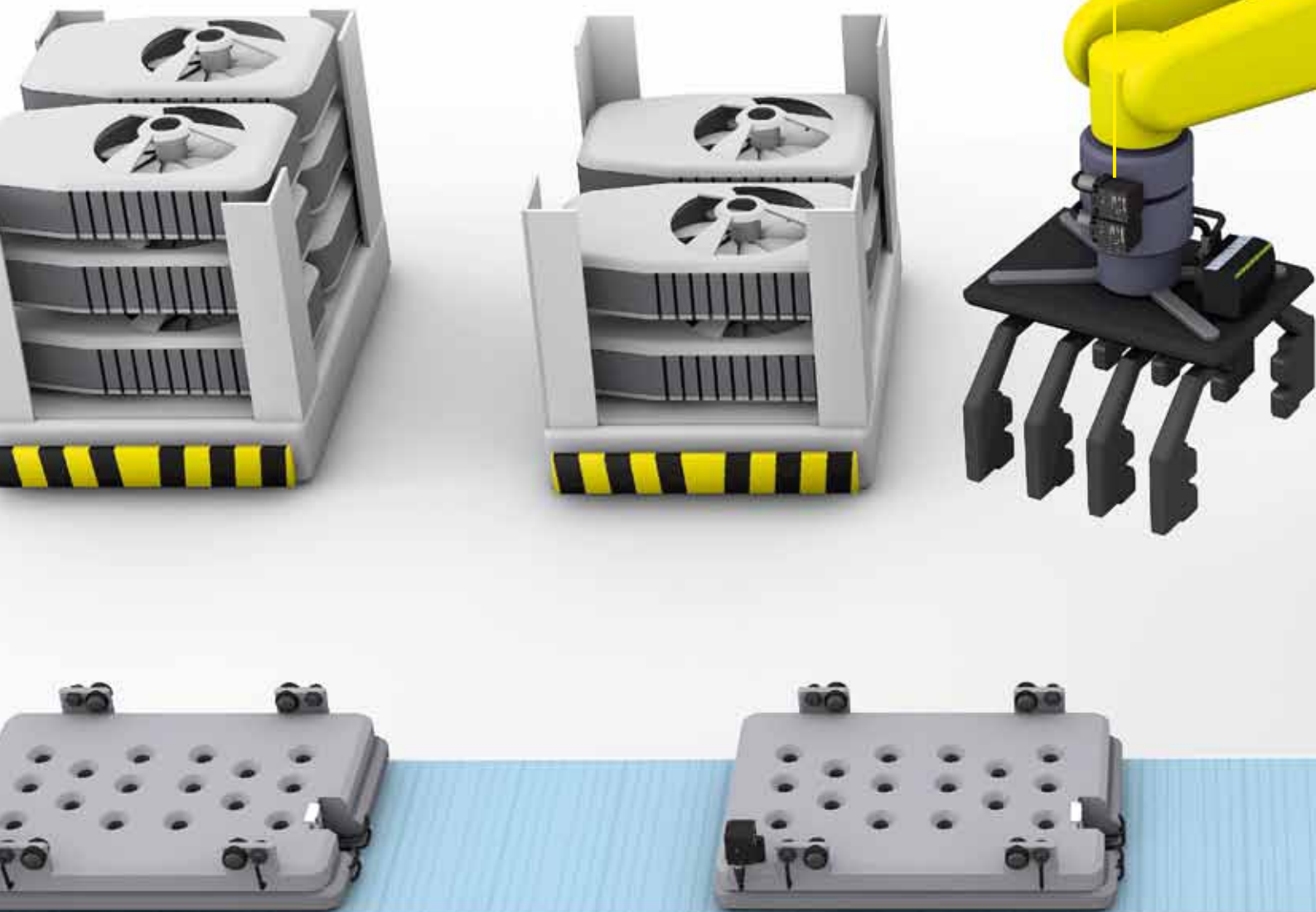



Benefits

- No warped, damaged pins
- No bending during coupling – axial offset is permissible
- No mechanical contact, no wear

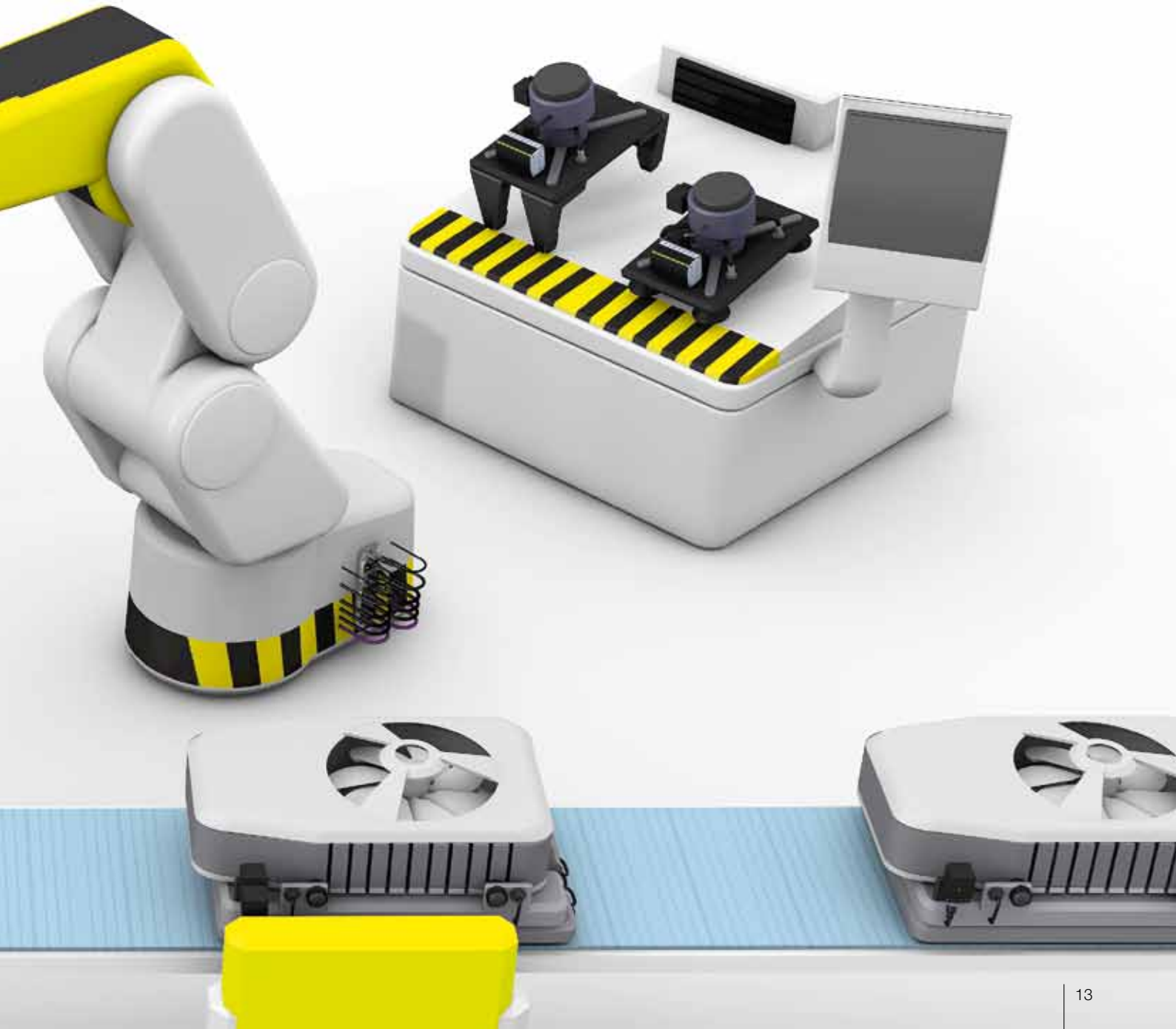



Principle of operation

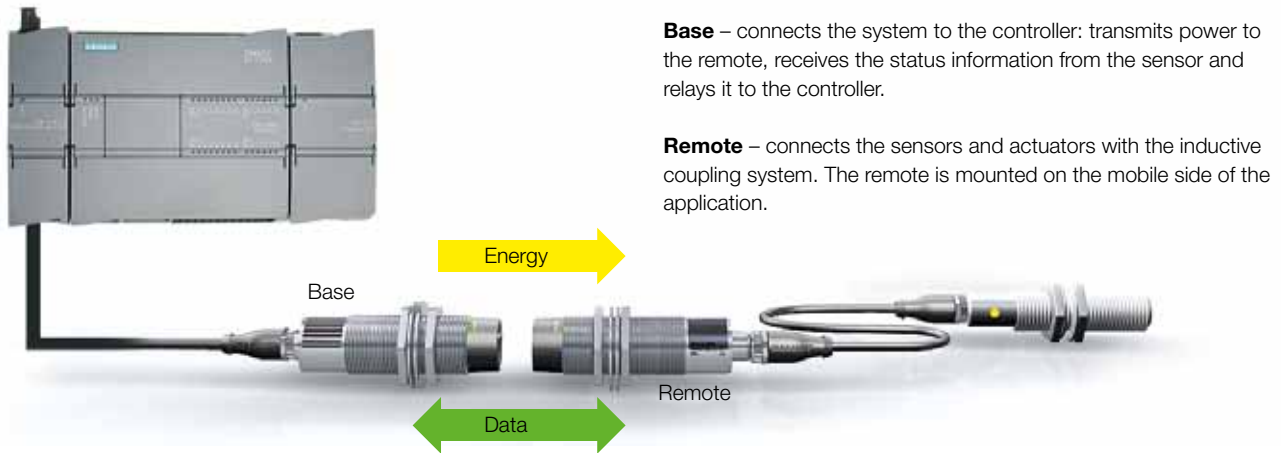

The benefits at a glance

Inductive couplers increase flexibility

- Simplified contacting and cable routing
- Radial coupling and axial rotation permissible
- Data transmission to previously inaccessible machine parts

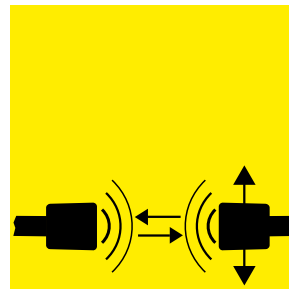

Inductive couplers offer a secure connection

- Digital data exchange, optimum signal quality
- Insensitive to vibrations, no contact chatter
- Can be used in harsh environments, in humidity, dust and oil (IP 67)

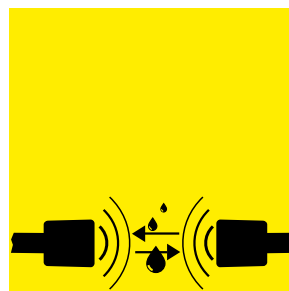

Inductive couplers overcome obstacles

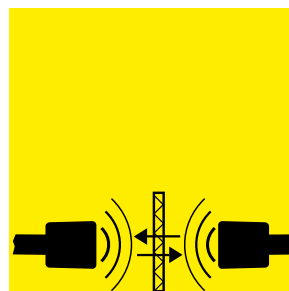

Establishment of a connection across even non-metallic obstacles – such as drill-free cable routing



Product overview

BIC M30 Uni-Standard, parallel Unidirectional



| | Uni-standard with 0.5 A power and 8 signals | |
|---------------------------------------|--|--|
| Size | M30×107.5 mm | M30×107 mm |
| Working range | 0...5 mm | 0...5 mm |
| Installation | non-flush | non-flush |
| Ordering code | BIC000A | BIC0009 |
| Part number | BIC 2I3-P2A50-M30MI3-SM4ACA | BIC 1I3-P2A50-M30MI3-SM4ACA |
| Number of signals | 8 digital | |
| Reliable offset | ±4 mm | ±4 mm |
| Transfer voltage | 24 V | |
| Continuous output current remote | 500 mA | |
| Transferable output | 12 W | 12 W |
| Degree of protection as per IEC 60529 | IP 67 | IP 67 |
| Housing material | CuZn coated | CuZn coated |
| Connection | M12 connector, female, 12-pin | M12 connector, male, 12-pin |
| |  |  |

Benefits

- Simple wiring of e.g. rotary tables and mobile machine components
- Up to 8 digital signals can be transmitted
- Control of capacitive loads
- High power density
- Simple installation with M12 connector
- IP 67
- Large working range (0 to 5 mm)
- Function display visible from every angle



Product overview

BIC M30 and BIC Q40 unidirectional



| | IO-Link interface 16 IN | | IO-Link interface 4x, analog | |
|---------------------------------------|------------------------------|-----------------------------|------------------------------|-----------------------------|
| Size | M30×107.5 mm | M30×100 mm | M30×107.5 mm | M30×100 mm |
| Working range | 0...5 mm | 0...5 mm | 0...5 mm | 0...5 mm |
| Installation | non-flush | non-flush | non-flush | non-flush |
| Ordering code | BIC000E | BIC000C | BIC0054 | BIC0053 |
| Part number | BIC 210-I2A50-M30MI3-SM4A5A | BIC 110-I2A50-M30MI3-SM4A4A | BIC 210-IAA50-M30MI3-SM4A5A | BIC 110-IAA50-M30MI3-SM4A4A |
| Reliable offset | ±4 mm | ±4 mm | ±4 mm | ±4 mm |
| Transfer voltage | 24 V | 24 V | 24 V | 24 V |
| Continuous output current remote | 500 mA | | 500 mA | |
| Transferable output | 12 W | 12 W | 12 W | 12 W |
| Degree of protection as per IEC 60529 | IP 67 | IP 67 | IP 67 | IP 67 |
| Housing material | CuZn coated | CuZn coated | CuZn coated | CuZn coated |
| Connection | M12 connector, female, 5-pin | M12 connector, male, 4-pin | M12 connector, female, 5-pin | M12 connector, male, 4-pin |
| | | | | |

IO-Link

| | | | | |
|-----------------------------|---------------|---------------|----------------|----------------|
| Transfer rate | 38.4 kbaud | 38.4 kbaud | 38.4 kbaud | 38.4 kbaud |
| Cycle time min. | 3 ms | 3 ms | 3 ms | 3 ms |
| Process data cycle | 12 ms | 12 ms | 33 ms | 33 ms |
| IO-Link process data length | 3 input bytes | 3 input bytes | 11 input bytes | 11 input bytes |
| Frame type | 1 | 1 | 1 | 1 |

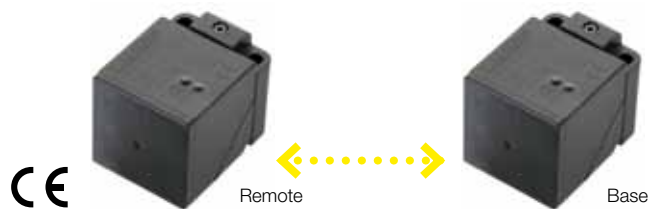

| | IO-Link | |
|---------------------------------------|---------------------------------------|-------------------------------------|
| Size | 40×40×63 mm | 40×40×63 mm |
| Working range | 1 mm...5 mm | 1 mm...5 mm |
| Ordering code | BIC005C | BIC005A |
| Part number | BIC 210-I2A50-Q40KFU-SM4A5A | BIC 110-I2A50-Q40KFU-SM4A4A |
| Reliable offset | ±5 mm | ±5 mm |
| Transfer voltage | 24 V | 24 V |
| Continuous output current remote | 500 mA | |
| Transferable output | 12 W | 12 W |
| Degree of protection as per IEC 60529 | IP 67 | IP 67 |
| Housing material | PBTP | PBTP |
| Connection | M12 connector, female, 5-pin, A-coded | M12 connector, male, 4-pin, A-coded |
| | | |



IO-Link

| | | |
|-----------------------------|---------------|-----------------------------|
| Transfer rate | 38.4 kbaud | 38.4 kbaud |
| Cycle time min. | 3 ms | 3 ms |
| Process data cycle | | 12 ms at minimum cycle time |
| IO-Link process data length | 3 input bytes | 3 input bytes |
| Frame type | 1 | 1 |

Product overview

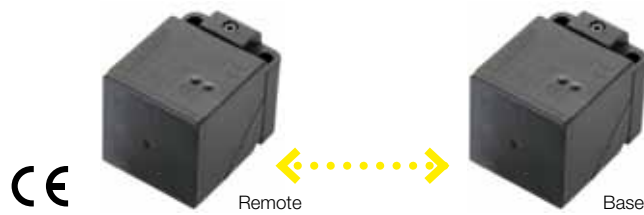
BIC Q40 bidirectional



| | IO-Link | |
|---------------------------------------|---|---|
| Size | 40×40×63 mm | 40×40×63 mm |
| Working range | 1...5 mm | 1...5 mm |
| Ordering code | BIC0070 | BIC0071 |
| Part number | BIC 1B0-ITA50-Q40KFU-SM4A4A | BIC 2B0-ITA50-Q40KFU-SM4A5A |
| Reliable offset | ±5 mm | ±5 mm |
| Transfer voltage | 24 V | 24 V |
| Continuous output current remote | 500 mA | |
| Transferable output | 12 W | 12 W |
| Degree of protection as per IEC 60529 | IP 67 | IP 67 |
| Housing material | PBTP | PBTP |
| Connection | M12 connector, male, 4-pin, A-coded  | M12 connector, female, 5-pin, A-coded  |
| IO-Link Version 1.1 | | |
| Transfer rate | COM 2 | COM 2 |
| Cycle time min. | depends on IO-Link device | depends on IO-Link device |
| IO-Link process data length | 1...32 byte | 1...32 byte |
| SIO mode | no | no |

Benefits

- Simultaneous activation of actuators and collection of sensor signals
- AUX power for actuators can be switched on and off
- Simplest installation via plug and play
- Transparent communication
- Full IO-Link functionality up to the device
- Flexible adaptation of process data length to the IO-Link device
- Full IO-Link diagnosis functionality
- Switching off of power if the remote is uncoupled

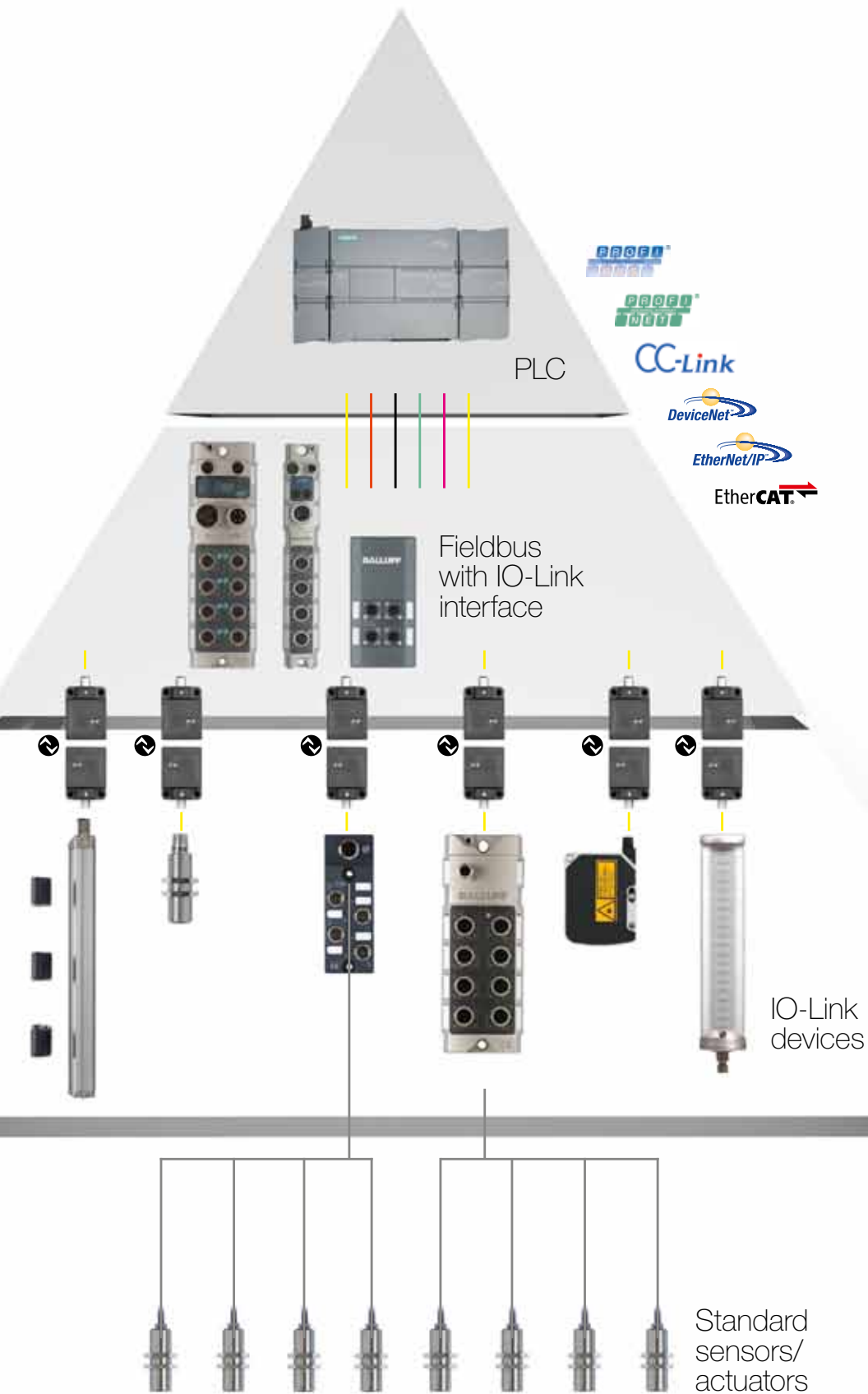
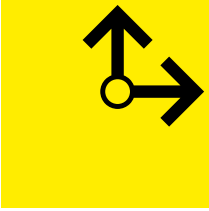

Continuous communication with IO-Link

IO-Link simplifies processes

The interface IO-Link can be used universally and is fieldbus-independent; it transmits all sensor signals to the controller and, conversely, relays all control data to the actuators. As a result, IO-Link integrates all sensors into the fieldbus structure and enables comprehensive ongoing diagnostics and automated configuration of parameters for IO-Link devices via the controller. IO-Link is easy to install. An unshielded standard industrial cable is all that is needed

for any transmission task. All connections are established via M5, M8 and M12 connectors with unshielded 3-wire standard cables. At the end of the day, IO-Link simplifies network topology while saving time and money. IO-Link helps you maximize every technical opportunity.

Inductive couplers offer IO-Link functionality

Simplification of installation

When coupled to IO-Link, inductive couplers can be used to accomplish demanding tasks. Power and process data are reliably and flexibly transmitted from a wide variety of IO-Link devices. As a result, up to 16 sensor signals can be transported over a single 3-wire cable via sensor hubs, for example. The IO-Link interface therefore significantly reduces the amount of wiring required for the parallel transfer.

Simultaneous transmission of analog and digital signals

The BIC inductive coupler with IO-Link enables simultaneous transmission of analog and digital signals in such a way that even signals from measuring systems can be transmitted without contact.

Interference-free transmission

- Exchange data only where necessary
- Digital, no interference with neighboring areas

Plug and play

The contactless data transmission with IO-Link standard has a transparent structure. This means the BIC system behaves "invisibly" and can be incorporated between master and device without configuring via plug and play.

Regardless of the IO-Link revision status, the system has a full-fledged IO-Link interface. Events, parameter data and process data are directly exchanged between master and device.

Mechanically disconnected and electrically connected:

BIC bidirectional – the contactless IO-Link interface transmits data in both directions

- Simultaneous activation of actuators and collection of sensor signals
- AUX power for actuators can be switched on and off
- Full IO-Link functionality up to the device
- Flexible process data length

Areas of application

- Rotary index tables (in assembly and machine tool)
- Workpiece carriers (e.g. workpiece clamping devices in press welding systems)
- Machines with change tools (presses, injection molding tools)

BALLUFF

sensors worldwide



Systems and Service



Industrial Networking and Connectivity



Industrial Identification



Object Detection



Position and Distance Measurement



Status Monitoring and Fluid Sensors



Accessories

Headquarters

Balluff GmbH
Schurwaldstrasse 9
73765 Neuhausen a.d.F.
Germany
Phone +49 7158 173-0
Fax +49 7158 5010
balluff@balluff.de



www.balluff.com